

# Panasonic®

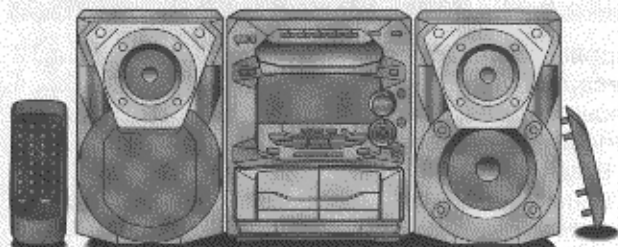

## CD Stereo System

### Operating Instructions

Model No. **SC-AK14**

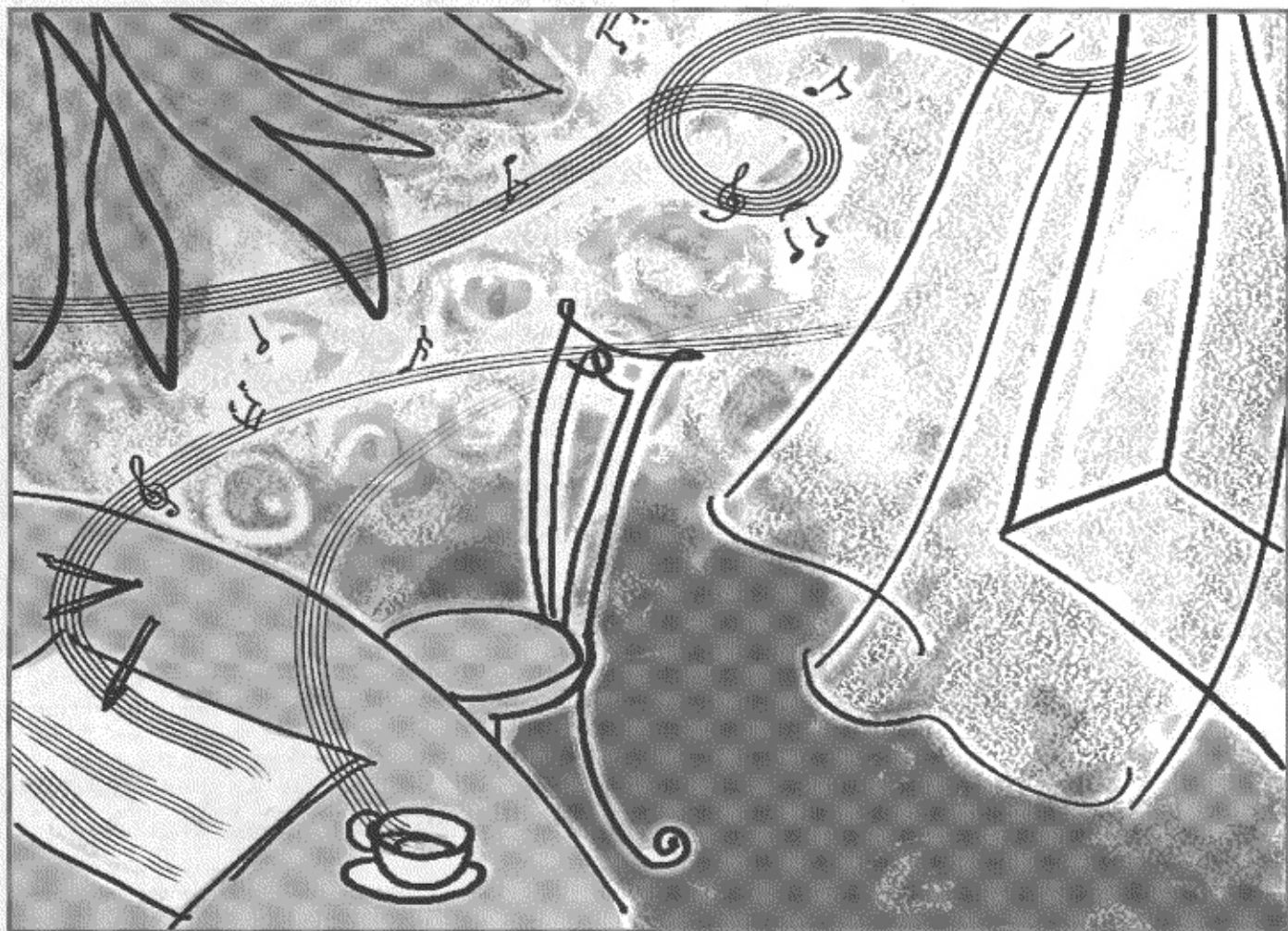

COMPACT  
**disc**  
DIGITAL AUDIO

Before connecting, operating or adjusting this product, please read these instructions completely.  
Please keep this manual for future reference.

## Dear customer

Thank you for purchasing this product.  
For optimum performance and safety, please read these instructions carefully.

These operating instructions are applicable to the following system.

|                  |         |
|------------------|---------|
| <b>System</b>    | SC-AK14 |
| <b>Main unit</b> | SA-AK14 |
| <b>Speakers</b>  | SB-AK18 |

The model number and serial number of this product can be found on either the back or the bottom of the unit. Please note them in the space provided below and keep for future reference.

MODEL NUMBER \_\_\_\_\_

SERIAL NUMBER \_\_\_\_\_

### User memo:

DATE OF PURCHASE \_\_\_\_\_

DEALER NAME \_\_\_\_\_

DEALER ADDRESS \_\_\_\_\_

TELEPHONE NUMBER \_\_\_\_\_

### CAUTION!

**THIS PRODUCT UTILIZES A LASER.  
USE OF CONTROLS OR ADJUSTMENTS OR PERFORMANCE OF PROCEDURES OTHER THAN THOSE SPECIFIED HEREIN MAY RESULT IN HAZARDOUS RADIATION EXPOSURE. DO NOT OPEN COVERS AND DO NOT REPAIR YOURSELF. REFER SERVICING TO QUALIFIED PERSONNEL.**

### WARNING:

**TO REDUCE THE RISK OF FIRE, ELECTRIC SHOCK OR PRODUCT DAMAGE, DO NOT EXPOSE THIS APPLIANCE TO RAIN, SPLASHING, DRIPPING OR MOISTURE.**

## Table of contents

### Before using

|  |    |
|--|----|
| Supplied accessories .....                         | 2  |
| Precautions .....                                  | 4  |
| Placement of speakers .....                        | 5  |
| Concerning the remote control .....                | 5  |
| Battery installation .....                         | 5  |
| Correct method of use .....                        | 5  |
| Connections .....                                  | 6  |
| Basic connections (for supplied accessories) ..... | 6  |
| Optional antenna connections .....                 | 7  |
| External unit connection .....                     | 7  |
| Front panel controls .....                         | 8  |
| Turning the demo function off .....                | 10 |
| ECO mode .....                                     | 10 |
| Auto-off function .....                            | 10 |
| Setting the time .....                             | 11 |
| Convenient functions .....                         | 11 |

### Radio operations

|                                     |    |
|-------------------------------------|----|
| Presetting radio broadcasts .....   | 12 |
| Listening to radio broadcasts ..... | 13 |

### Compact disc operations

|  |    |
|--|----|
| Concerning compact discs .....                                     | 14 |
| Listening to compact discs .....                                   | 15 |
| Direct access play .....   | 16 |
| Repeat play .....  | 16 |
| Random play .....  | 16 |
| Program play .....   | 17 |
| To listen to special CDs and tracks<br>(CD Manager function) ..... | 18 |

### Cassette deck operations

|                                 |    |
|---------------------------------|----|
| Listening to tapes .....        | 19 |
| Concerning cassette tapes ..... | 20 |

## Supplied accessories

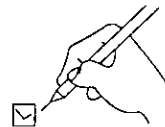

Please check and identify the supplied accessories.

Use numbers indicated in parentheses when asking for replacement parts.

To order accessories contact 1-800-332-5368 or web site (<http://www.panasonic.com>).

- AC power supply cord ..... 1 pc.  
(RJA0065-A)

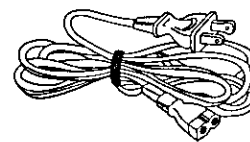

- FM indoor antenna (RSA0006-J) ..... 1 pc.



**Recording operations**

**Before recording (Deck 2 only) ..... 21**  
**Tape-to-tape recording ..... 21**  
**Recording from radio broadcasts ..... 22**  
**Recording from compact discs ..... 23**  
 To record special CDs and tracks  
 (CD Manager function) ..... 24

**Sound quality/sound field operations**

**Using the built-in sound quality/  
 sound field settings ..... 25**  
**Adding bass ..... 25**  
**Varying the sound quality with the manual  
 equalizer ..... 26**  
**Varying the sound quality with  
 the acoustic image (AI) equalizer ..... 26**

**Timer operations**

**Using the timer ..... 27**  
 Using the play/record timer ..... 27  
 Using the sleep timer ..... 29

**Reference**

**Using an external unit ..... 29**  
**Troubleshooting guide ..... 30**  
**Maintenance ..... 31**  
**Specifications ..... Back Cover**  
**Product service ..... Back Cover**

**CAUTION:**

This equipment has been tested and found to comply with the limits for a Class B digital device, pursuant to Part 15 of the FCC Rules.

These limits are designed to provide reasonable protection against harmful interference in a residential installation. This equipment generates, uses and can radiate radio frequency energy and, if not installed and used in accordance with the instructions, may cause harmful interference to radio communications. However, there is no guarantee that interference will not occur in a particular installation. If this equipment does cause harmful interference to radio or television reception, which can be determined by turning the equipment off and on, the user is encouraged to try to correct the interference by one of the following measures:

- Reorient or relocate the receiving antenna.
- Increase the separation between the equipment and receiver.
- Connect the equipment into an outlet on a circuit different from that to which the receiver is connected.
- Consult the dealer or an experienced radio/TV technician for help.

Any unauthorized changes or modifications to this equipment would void the user's authority to operate this device.

This device complies with Part 15 of the FCC Rules. Operation is subject to the following two conditions: (1) This device may not cause harmful interference, and (2) this device must accept any interference received, including interference that may cause undesired operation.



**CAUTION**

RISK OF ELECTRIC SHOCK  
DO NOT OPEN



CAUTION: TO REDUCE THE RISK OF ELECTRIC SHOCK, DO NOT REMOVE SCREWS. NO USER-SERVICEABLE PARTS INSIDE. REFER SERVICING TO QUALIFIED SERVICE PERSONNEL.

- AM loop antenna (RSA0029) ..... 1 pc.       Batteries ..... 2 pcs. (R6, AA, UM-3)

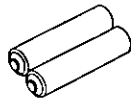
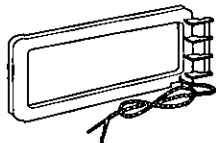

- Remote control transmitter (EUR648200) ..... 1 pc.



The lightning flash with arrowhead symbol, within an equilateral triangle, is intended to alert the user to the presence of uninsulated "dangerous voltage" within the product's enclosure that may be of sufficient magnitude to constitute a risk of electric shock to persons.



The exclamation point within an equilateral triangle is intended to alert the user to the presence of important operating and maintenance (servicing) instructions in the literature accompanying the appliance.

# PRECAUTIONS

Before using this unit please read these operating instructions carefully. Take special care to follow the warnings indicated on the unit itself as well as the safety suggestions listed below. Afterwards keep them handy for future reference.

## Safety

- 1. Power Source**—The unit should be connected to power supply only of the type described in the operating instructions or as marked on the unit.
- 2. Polarization**—If the unit is equipped with a polarized AC power plug (a plug having one blade wider than the other), that plug will fit into the AC outlet only one way. This is a safety feature. If you are unable to insert the plug fully into the outlet, try reversing the plug. If the plug should still fail to fit, contact your electrician to replace your obsolete outlet. Do not defeat the safety purpose of the polarized plug.
- 3. Power Cord Protection**—AC power supply cords should be routed so that they are not likely to be walked on or pinched by items placed upon or against them. Never take hold of the plug or cord if your hand is wet, and always grasp the plug body when connecting or disconnecting it.
- 4. Nonuse Periods**—When the unit is not used, turn the power off. When left unused for a long period of time, the unit should be unplugged from the household AC outlet.

## Installation

### Environment

- 1. Outdoor Antenna Grounding**—If an outside antenna is connected to the receiver, be sure the antenna system is grounded so as to provide some protection against voltage surges and built-up static charges. Section 810 of the National Electrical Code, ANSI/NFPA No. 70-1990, provides information with respect to proper grounding of the mast and supporting structure, grounding of the lead-in wire to an antenna discharge unit, size of grounding conductors, location of antenna-discharge unit, connection to grounding electrodes, and requirements for the grounding electrode. See figure below.

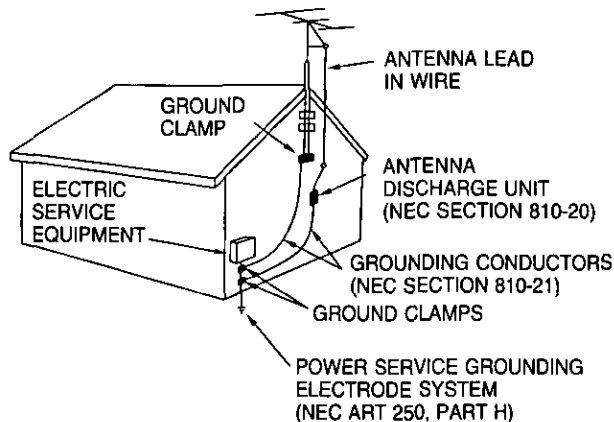

NEC—NATIONAL ELECTRICAL CODE

- 2. Water and Moisture**—Do not use this unit near water—for example, near a bathtub, washbowl, swimming pool, or the like. Damp basements should also be avoided.

- 3. Heat**—The unit should be situated away from heat sources such as radiators and the like. It also should not be placed in temperatures less than 5°C (41°F) or greater than 35°C (95°F).
- 4. Condensation**—Moisture may form on the lens in the following conditions...
  - immediately after a heater has been turned on.
  - in a steamy or very humid room.
  - when the unit is suddenly moved from a cold environment to a warm one.If moisture forms inside this unit, it may not operate properly. To correct this problem, turn on the power and wait about one hour for the moisture to evaporate.

### Placement

- 1. Ventilation**—The unit should be situated so that its location or position does not interfere with its proper ventilation. Allow 10 cm (4") clearance from the rear of the unit.
- 2. Foreign Material**—Care should be taken so that objects do not fall into and liquids are not spilled into the unit. Do not subject this unit to excessive smoke, dust, mechanical vibration, or shock.
- 3. Magnetism**—The unit should be situated away from equipment or devices that generate strong magnetic fields.
- 4. Stacking**—Do not place heavy objects, other than system components, on top of the unit.
- 5. Surface**—Place the unit on a flat, level surface.
- 6. Carts and Stands**—The unit should be used only with a cart or stand that is recommended by the manufacturer. The unit and cart combination should be moved with care. Quick stops, excessive force, and uneven surfaces may cause the unit and cart combination to overturn.
- 7. Wall or Ceiling Mounting**—The unit should not be mounted to a wall or ceiling, unless specified in this operating instructions.

### Maintenance

(See page 31 for details.)

Clean the cabinet, panel and controls with a soft cloth lightly moistened with mild detergent solution. Do not use any type of abrasive pad, scouring powder or solvent such as alcohol or benzene.

### Service

- 1. Damage Requiring Service**—The unit should be serviced by qualified service personnel when:
  - (a) The AC power supply cord or the plug has been damaged; or
  - (b) Objects have fallen or liquid has been spilled into the unit; or
  - (c) The unit has been exposed to rain; or
  - (d) The unit does not appear to operate normally or exhibits a marked change in performance; or
  - (e) The unit has been dropped, or the enclosure damaged.
- 2. Servicing**—The user should not attempt to service the unit beyond that described in the operating instructions. All other servicing should be referred to an authorized service personnel.

*For the address of an authorized servicenter:  
in the U.S.A. 1-800-211-7262 or web site  
(<http://www.panasonic.com>)*

## Listening caution



Selecting fine audio equipment such as the unit you've just purchased is only the start of your musical enjoyment. Now it's time to consider how you can maximize the fun and excitement your equipment offers. This manufacturer and the Electronic Industries Association's Consumer Electronics Group want you to get the most out of your equipment by playing it at a safe level. One that lets the sound come through loud and clear without annoying blaring or distortion—and, most importantly, without affecting your sensitive hearing.

We recommend you to avoid prolonged exposure to excessive noise.

Sound can be deceiving. Over time your hearing "comfort level" adapts to higher volumes of sound. So what sounds "normal" can actually be loud and harmful to your hearing. Guard against this by setting your equipment at a safe level BEFORE your hearing adapts.

To establish a safe level:

- Start your volume control at a low setting.
- Slowly increase the sound until you can hear it comfortably and clearly, and without distortion.

Once you have established a comfortable sound level:

- Set the dial and leave it there.

Taking a minute to do this now will help to prevent hearing damage or loss in the future. After all, we want you listening for a lifetime.

## Placement of speakers

Speakers are designed identically so that no left or right channel orientation is necessary.

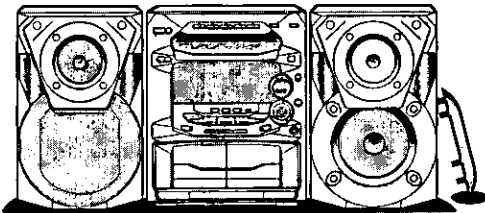

### Notes

- Keep your speakers at least 10 mm ( $13/32$ " ) away from the system for proper ventilation.
- These speakers do not have magnetic shielding. Do not place them near televisions, personal computers or other devices easily influenced by magnetism.
- To avoid damage to the speakers, do not touch the speakers cones if you have taken the nets off.

## Concerning the remote control

### Battery installation

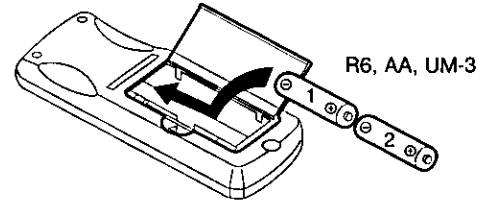

Insert the batteries observing the correct polarities (+, -).

### Use of batteries

- Align the poles (+ and -) properly when inserting the batteries.
- Do not mix old and new batteries or different types of batteries.
- Do not recharge ordinary dry cell batteries.
- Do not heat or disassemble the batteries. Do not allow them to contact flame or water.
- Remove the batteries if the unit is not to be used for a long time.
- Do not keep together with metallic objects such as necklaces.
- Do not use batteries if the covering has been peeled off.
- Do not use rechargeable type batteries.

Mishandling of batteries can cause electrolyte leakage which can damage items the fluid contacts and may cause a fire.

If electrolyte leaks from the batteries, consult your dealer.

Wash thoroughly with water if electrolyte comes in contact with any part of your body.

### Correct method of use

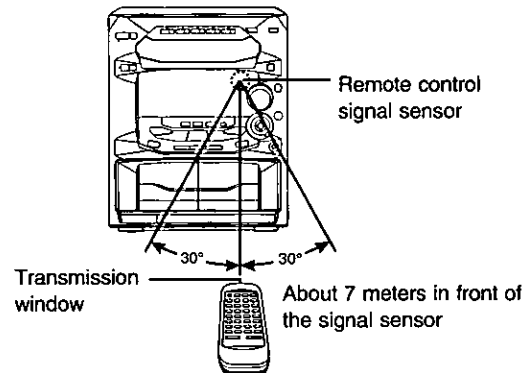

### Operation notes

- Do not place obstacles between the remote control signal sensor and remote control unit.
- Do not expose the remote control signal sensor to direct sunlight or to the bright light of a fluorescent light.
- Take care to keep the remote control signal sensor and end of the remote control unit free from dust.
- If this system is installed in a rack with glass doors, the glass doors' thickness or color might make it necessary to use the remote control a shorter distance from the system.

### To prevent damage

- Never place heavy items on top of the unit.
- Do not disassemble or reconstruct the unit.
- Do not spill water or other liquids into the unit.

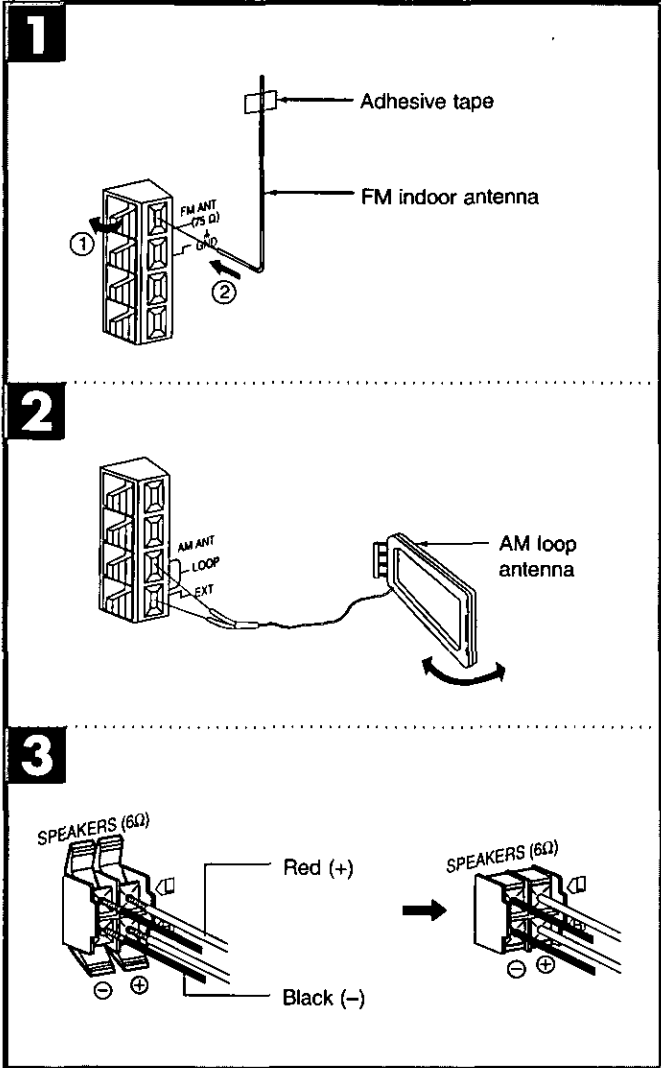
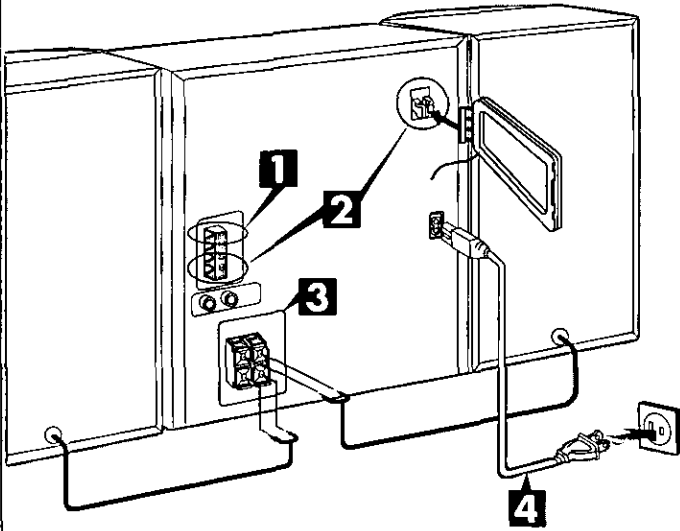

## Connections

### Basic connections (for supplied accessories)

- Plug the AC power cord into a household AC outlet only after all other connections have been made.
- To prepare the antenna wires and speaker cords, twist the vinyl cover tip and pull off.

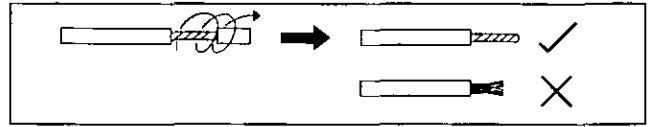

- 1 Connect the FM indoor antenna.**  
Tape the antenna to a wall or column, in a position where radio signals are received with the least amount of interference.

**Note**

**For best reception sound quality:**  
An FM outdoor antenna is recommended. (See page 7.)

- 2 Connect the AM loop antenna.**  
After attaching the antenna, turn on the system and tune in a broadcast station. Then, turn the antenna to the angle of best reception and least interference.

- 3 Connect the speaker cables.**  
Connect each end of the speaker cables to the terminal lever of the same color.

**Caution**

- **Use only the supplied speakers.**  
The combination of the main unit and speakers provide the best sound. Using other speakers can damage the unit and sound quality will be negatively affected.
- To prevent damage to circuitry, never short-circuit positive (+) and negative (-) speaker wires.

**Caution**

- **Use the speakers only with the recommended system.**  
Failure to do so may lead to damage to the amplifier and/or the speakers, and may result in the risk of fire.
- **Consult a qualified service person if damage has occurred or if you experience a sudden change in performance.**
- **Do not attach these speakers to walls or ceilings.**

- 4 Connect the AC power cord.**  
**Note**  
The included AC power supply cord is for use with this unit only. Do not use it with other equipment.

## Connections

### Optional antenna connections

You may need an outdoor antenna if you use this system in a mountainous region or inside a reinforced-concrete building, etc.

#### FM outdoor antenna **A**

Disconnect the FM indoor antenna if an FM outdoor antenna is installed.

- 1 Remove a piece of the outer vinyl insulator.
- 2 Twist the shield braid.
- 3 Expose the core wire.

#### Note

An outdoor antenna should be installed by a qualified technician only.

#### AM outdoor antenna **B**

Connect the outdoor antenna without removing the AM loop antenna. Run 5 to 12 m of vinyl-covered wire horizontally along a window or other convenient location.

#### Note

When the unit is not in use, disconnect the outdoor antenna to prevent possible damage that may be caused by lightning. Never use an outdoor antenna during an electrical storm.

#### External unit connection **C**

- An analog player with a built-in phono equalizer can be connected.
- For details, refer to the instruction manual of the units which are to be connected.
- When units other than those described above are to be connected, please consult with your audio dealer.

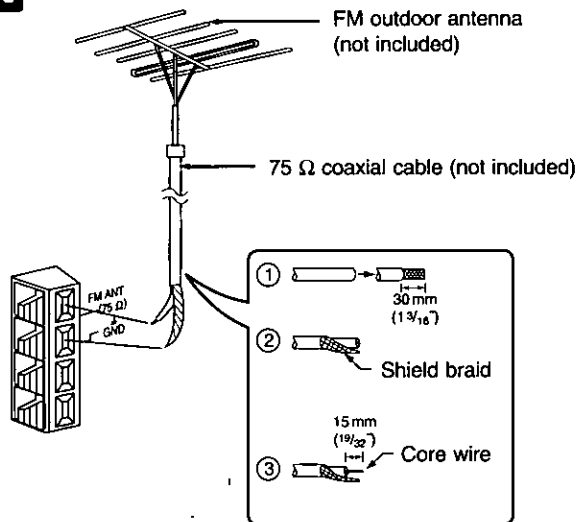
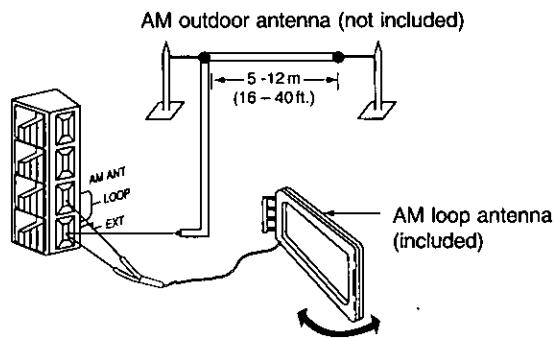
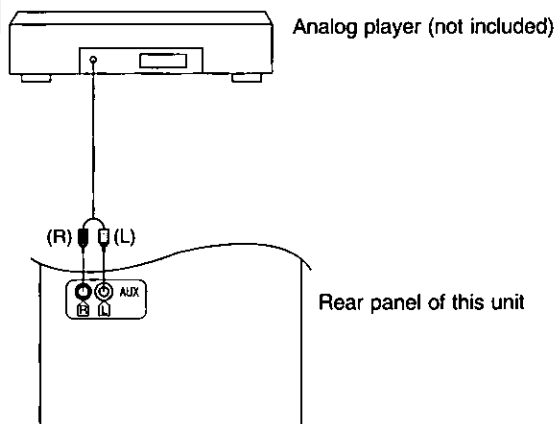
**A****B****C**

**A**

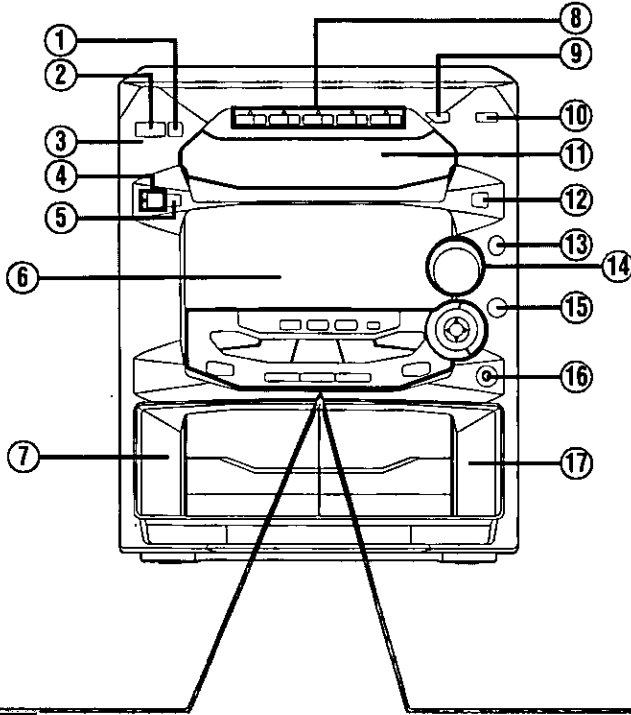

**B**

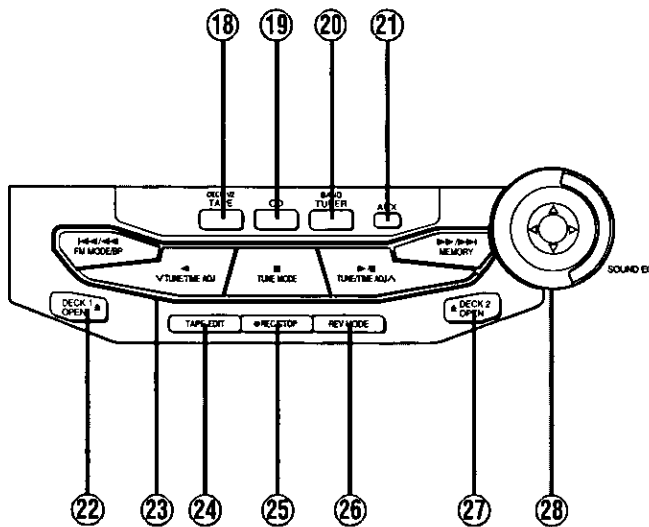

**Front panel controls**

**Main unit A**

| No. | Name  | Ref. page  |
|-----|---|------------|
| ①   | MODE button (NORMAL/ECO) (MODE) .....   | 10         |
| ②   | Standby/on switch (⏻/⏻, POWER).....   | 10         |
|     | Press to switch the unit from on to standby mode or vice versa. In standby mode, the unit is still consuming a small amount of power. |            |
| ③   | AC supply indicator (AC IN)   |            |
|     | This indicator lights when the unit is connected to the AC mains supply.  |            |
| ④   | Play timer/record timer button and indicator (⏻/⏻) .....  | 27         |
| ⑤   | Clock/timer button (CLOCK/TIMER).....   | 11, 27, 28 |
| ⑥   | Display   |            |
| ⑦   | Deck 1 cassette holder .....  | 19         |
| ⑧   | Disc direct play, open/close buttons and indicators (CD 1 ~ CD 5, ⏻) .....  | 15         |
| ⑨   | CD manager button (CD MANAGER) .....  | 18, 24     |
| ⑩   | Random play button (RANDOM) .....   | 16         |
| ⑪   | Disc tray   |            |
| ⑫   | Display select/demonstration button (-DISP/-DEMO) .....   | 10, 11     |
| ⑬   | V.BASS on/off button (V.BASS) .....   | 25         |
| ⑭   | Volume control (VOLUME) .....   | 13         |
| ⑮   | 3D AI EQ button (3D AI EQ) .....  | 26         |
| ⑯   | Headphone jack (PHONES) .....   | 29         |
| ⑰   | Deck 2 cassette holder .....  | 19         |

**Center console B**

| No. | Name   | Ref. page |
|-----|--|-----------|
| ⑱   | Tape/deck select button (TAPE, DECK 1/2) ..... | 19        |
| ⑲   | CD button (CD).....                            | 18        |
| ⑳   | Tuner/band select button (TUNER, BAND) .....   | 12        |
| ㉑   | AUX button (AUX) .....                         | 29        |
| ㉒   | Deck 1 open button (⏻ DECK 1 OPEN) .....       | 19        |
| ㉓   | Basic operating buttons                        |           |
|     | Functions change according to the source.      |           |
| ㉔   | Tape edit button (TAPE EDIT) .....             | 21        |
| ㉕   | Recording start/stop button (● REC/STOP) ..... | 22        |
| ㉖   | Reverse mode select button (REV MODE).....     | 19        |
| ㉗   | Deck 2 open button (⏻ DECK 2 OPEN) .....       | 19        |
| ㉘   | Sound equalizer control (SOUND EQ).....        | 25        |



## Front panel controls

### Remote control

Buttons such as ② function in exactly the same way as the buttons on the main unit.

| No. | Name | Ref. page |
|-----|------|-----------|
|-----|------|-----------|

|    |  |            |
|----|--|------------|
| ②  | Standby/on button (⏻)                                    | 10         |
| ②⑨ | Auto off button (AUTO OFF)                               | 10         |
| ③① | Numeric buttons (≥10, 1-0)                               | 13, 16     |
| ③① | Program button (PROGRAM)                                 | 17         |
| ③② | Cancel button (CANCEL)                                   | 17         |
| ①⑧ | Tape/deck select button (TAPE)                           | 19         |
| ①⑨ | CD button (CD)   | 18         |
| ③③ | EQ select button (EQ)                                    | 25         |
| ①⑤ | 3D AI EQ select button (3D AI)                           | 26         |
| ①⑧ | V.BASS on/off button (V.BASS)                            | 25         |
| ③④ | Reverse side playback/preset channel select button (◀/∇) | 13, 19     |
| ①④ | Volume buttons (- VOLUME +)                              | 13         |
| ③⑤ | Sleep button (SLEEP)                                     | 29         |
| ③⑥ | Muting button (MUTING)                                   | 11         |
| ③⑦ | Disc button (DISC)                                       | 16         |
| ①⑩ | Random button (RANDOM)                                   | 16         |
| ③⑧ | Repeat button (REPEAT)                                   | 16         |
| ②① | AUX button (AUX)   | 29         |
| ②① | Tuner/band select button (TUNER)                         | 12         |
| ③⑨ | Skip/search buttons (⏮/⏪, ⏩/⏭)                           | 15, 20     |
| ④① | Play/pause/preset channel select button (▶/⏸/△)          | 13, 15, 19 |
| ④① | Stop button (■)  | 15, 19     |

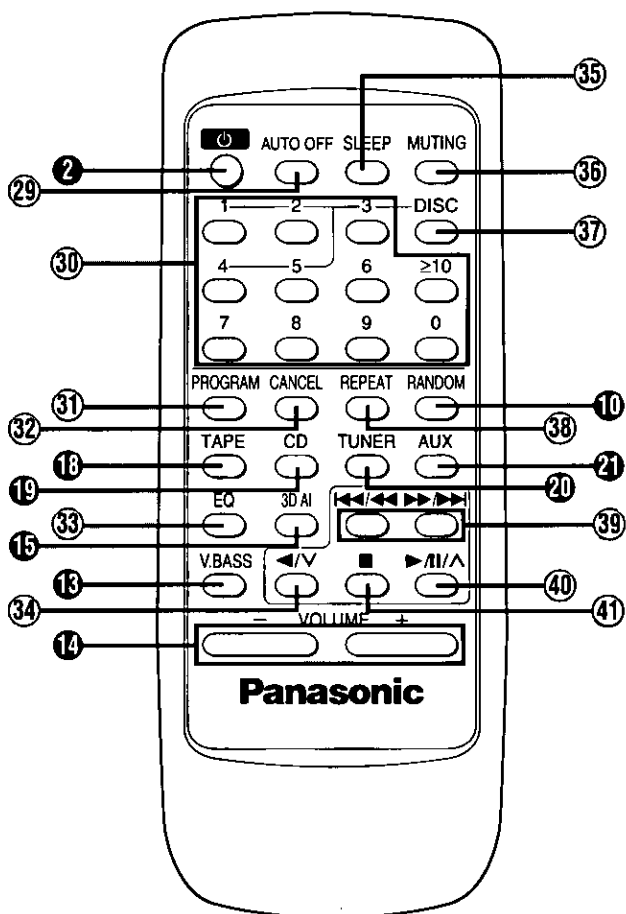

**A**

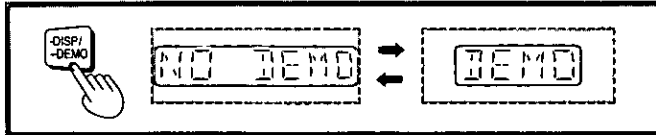
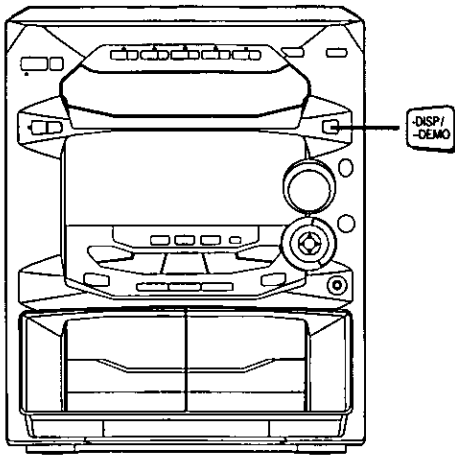

**B**

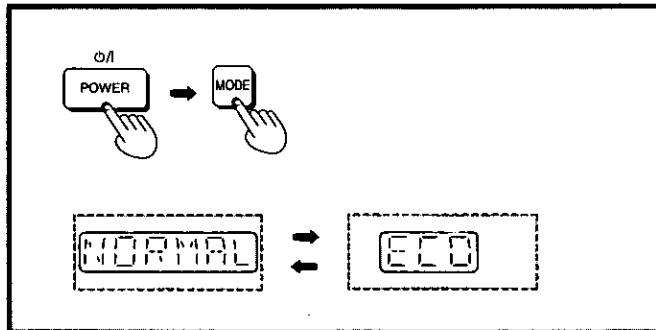
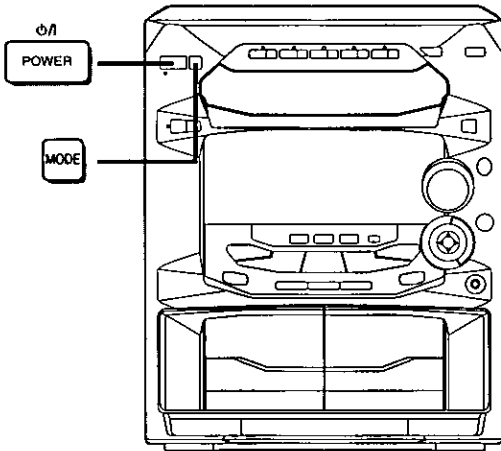

**C**

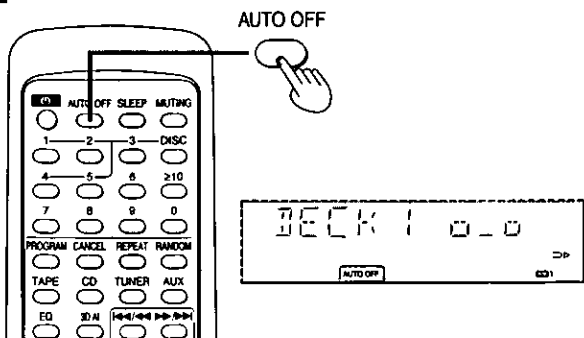

## Turning the demo function off **A**

If the clock has not been set, a demonstration of the display is shown when the unit is switched to standby.

This function is set to on at the time of purchase.

Turn this function off to get the most from the eco mode (see below).

**Press and hold [-DISP/-DEMO] until "NO DEMO" is displayed.**

The display changes each time the button is held down.

NO DEMO (off) ↔ DEMO (on)

## ECO mode **B**

When this mode is used, the display remains blank when the unit is switched to standby mode and the power consumed is reduced to 0.25W from a maximum of 18W.

The mode is set to on at the time of purchase.

| Condition in standby | Display | Power consumption |
|----------------------|---------|-------------------|
| ECO mode off         | clock   | 18W               |
| ECO mode on          | blank   | 0.25W             |

### Note

To get the most from this mode, turn the demo function off or set the clock.

Turning ECO on and off

**Press [⏻, POWER] to turn the unit on.**

**Press [MODE].**

The current ECO mode is displayed. Press again to change the mode.

The display changes each time the button is pressed.

NORMAL (off) ↔ ECO (on)

The eco mode can be turned on if the unit is in standby but it cannot be turned off.

### Conserving Power

The unit consumes 0.25W even when it is turned off with [⏻, POWER] or Auto-off function and ECO mode is turned on. To save power when the unit is not to be used for a long time, unplug it from the household AC outlet. Remember to reset the radio stations and any other memory items before using the unit again.

## Auto-off function **C**

### by remote control only

When CD or tape is selected as the source

To save power, the unit turns off if it is left unused for four minutes.

### Note

This function does not work if the source is tuner or AUX.

**Press [AUTO OFF].**

"AUTO OFF" is shown on the display.

### To cancel

Press [AUTO OFF] again to clear "AUTO OFF" from the display.

### For your reference

The setting is maintained even if the unit is turned off. When the unit is turned on again, "AUTO OFF" is displayed and the unit functions as described above.

"AUTO OFF" disappears from the display if either tuner or AUX is selected as the source but continues to function normally.

"AUTO OFF" remains displayed if CD or tape is selected as the source.

## Setting the time

This is a 12-hour display clock.  
This example in the figure shows how to set the time for 4:25 p.m..

- 1** Switch on the power.
- 2** Press [CLOCK/TIMER] to select "CLOCK".  
Every time you press the button:  
CLOCK → ⓄPLAY → ⓄREC  
↑ Previous display ↓
- 3** (within 7 seconds or so)  
Press [TUNE/TIME ADJ (V) or (^)] to show the present time.
- 4** Press [CLOCK/TIMER] to finish setting the time.  
The display will return to whatever was displayed before you set the time.

**To display the time when system is ON**  
Press [CLOCK/TIMER] to select "CLOCK".

**At ECO mode on, to display the time when system is OFF**  
Press [-DISP/-DEMO]. **A**

The time will be displayed for about 5 seconds and then the display will return to whatever was previously displayed.

## Convenient functions

### Switching displays **A**

Press [-DISP/-DEMO] to select the desired spectrum analyzer.  
Every time you press the button:  
Normal → Peak hold → Aurora → Wiper  
↑ (OFF) ↓

### To mute the volume **B**

**by remote control only**  
This feature is convenient when you have a telephone call, etc.

**Press [MUTING].**  
Press the button again to cancel.  
"MUTING" goes out.  
Muting can also be canceled by lowering the volume all the way (--dB).

When the system is turned off, the muting operation will be automatically canceled.

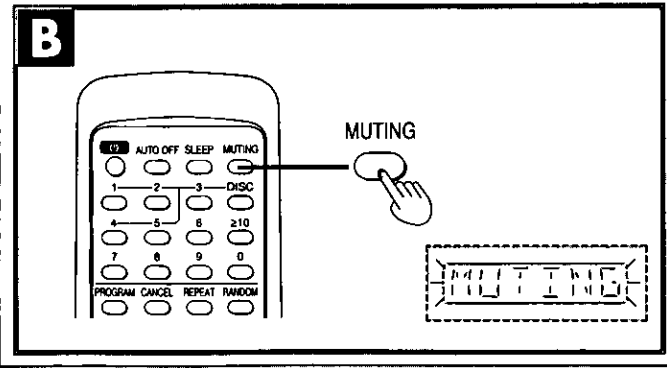
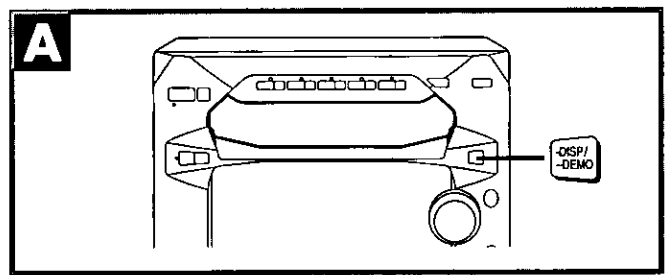
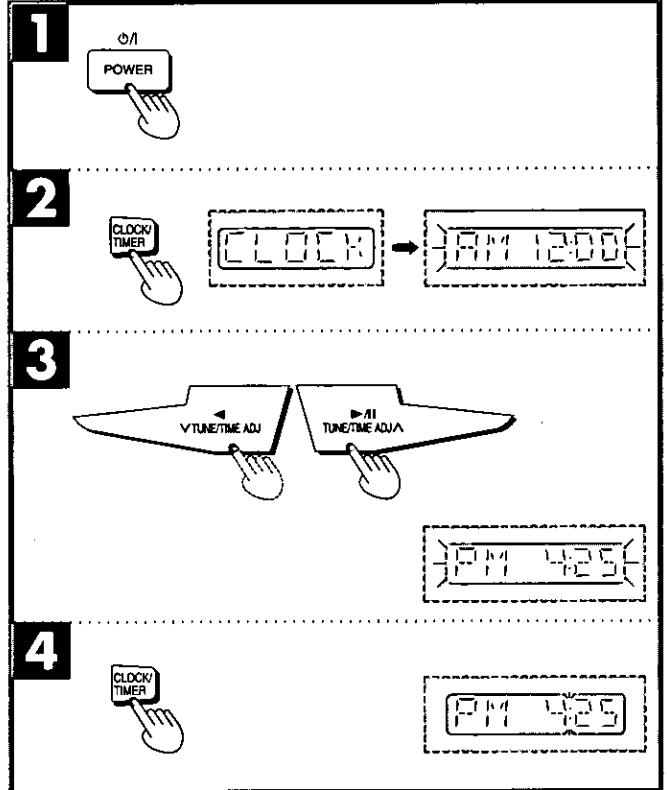
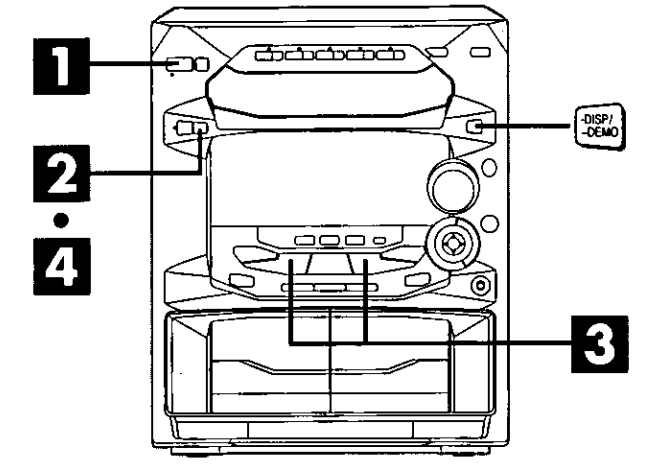

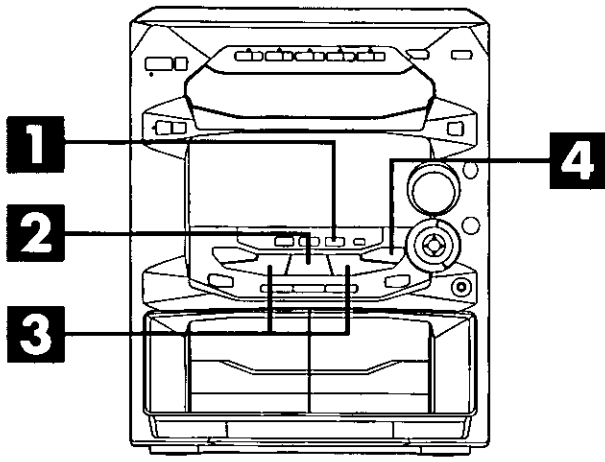

**1**

**2**

**3**

**4**

**Presetting radio broadcasts**

- Up to 12 stations can be set in each band with the automatic or manual memory presetting.
- If broadcast frequencies are preset in the memory, you can easily tune in any of these frequencies from the system or remote control unit.
- You can preset just those stations you like. (See "Presetting only your favorite stations" below.)

- 1** Press [TUNER, BAND] to select band.  
The system will come on automatically.  
Every time you press the button: FM ↔ AM
- 2** Press [■, TUNE MODE] to select "MANUAL".  
Every time you press the button: MANUAL ↔ PRESET.
- 3** Press [TUNE/TIME ADJ (∨) or (∧)] until the display shows the frequency from which you want to begin automatic memory presetting.

**Tips on tuning in radio stations**

- ① Hold down either arrow button until the frequency numbers start scrolling.
- ② When near to the frequency you are looking for, press the button repeatedly until the station is tuned in.

- 4** Press and hold [▶▶/▶▶, MEMORY] until the frequency begins to change.  
This will start presetting automatically. When finished, the radio will tune in the last station memorized.

If auto presetting is not possible because radio signals are weak or for some other reasons, do the following.

**Presetting only your favorite stations**

- Preset the stations one at a time.**
1. Perform step **1** above. Then, press [▶▶/▶▶, MEMORY] ("MEMO" flashes) and select a station with [TUNE/TIME ADJ (∨) or (∧)].
  2. While "MEMO" is flashing, press [▶▶/▶▶, MEMORY] again and select a preset channel with [TUNE/TIME ADJ (∨) or (∧)].
  3. Press [▶▶/▶▶, MEMORY] to preset the station.

**Memory retention**  
Your preset is retained in memory for about 2 weeks while the system is unplugged.

**FM allocation setting**

By adjusting the allocation, you can enable this tuner to receive FM broadcasts allocated in 0.1 MHz steps.

Press and hold [TUNER, BAND]. After a few seconds, the display will change to a flashing display of the current minimum FM frequency. If you continue to hold the button down, the minimum frequency will change. Release the button at this time.

To return to the original frequency indication, repeat above.

**Note**  
After changing the "allocation" setting, the frequencies you previously preset in the memory will be cleared.

## Listening to radio broadcasts

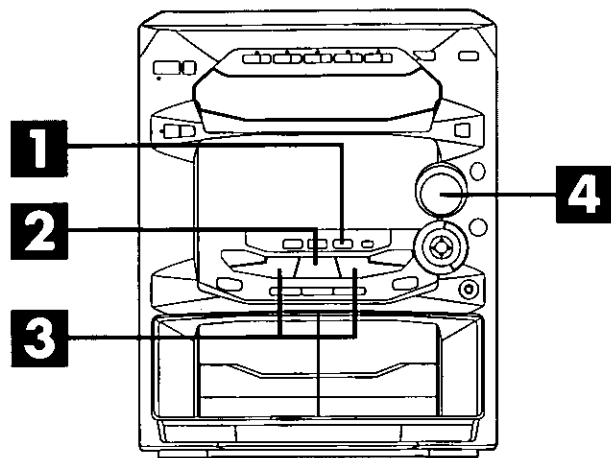

- 1** Press [TUNER, BAND] to select band.  
The unit will come on automatically.

- 2** Press [■, TUNE MODE] to select "PRESET" or "MANUAL".  
Every time you press the button: MANUAL ↔ PRESET.

PRESET: For preset stations  
MANUAL: For non-preset stations

- 3** Press [TUNE/TIME ADJ (∇) or (∧)] to select the desired broadcast.  
"STEREO" lights when an FM stereo broadcast is being received.  
"TUNED" lights when you precisely tune in a broadcast station.

- 4** Adjust the volume level.

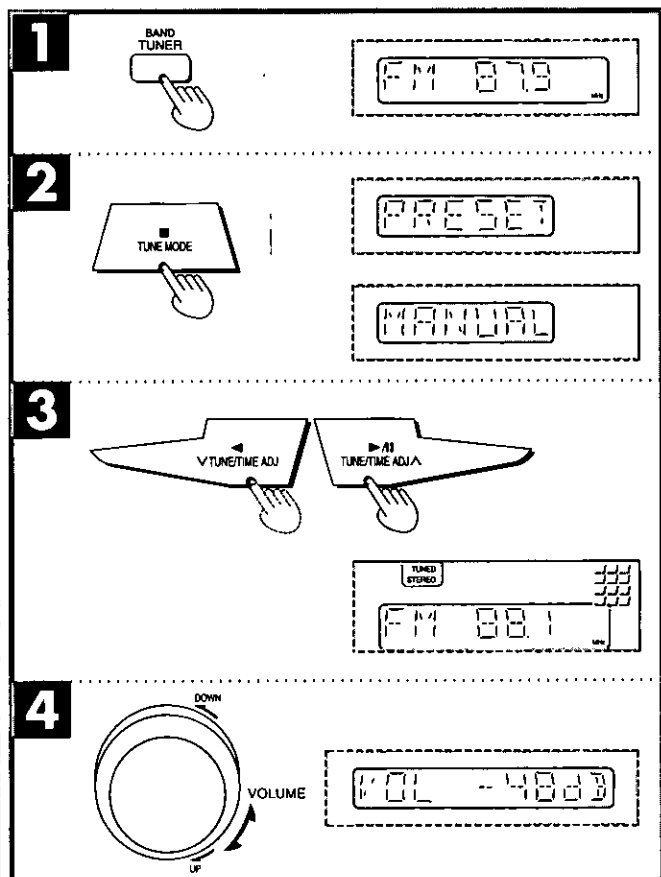

### Auto tuning

Auto tuning is an easy way to tune in non-preset stations in the manual mode.

Hold down either [TUNE/TIME ADJ (∇) or (∧)], and release the button when the frequency starts scrolling.

The frequency will stop scrolling automatically on the first station it picks up.

- When there is outside interference, the radio sometimes stops on a certain frequency where no station is broadcasting.

### To stop auto tuning

Press either [TUNE/TIME ADJ (∇) or (∧)] again.

### If noise is excessive in the FM stereo mode **A**

Press [◀◀/▶▶, FM MODE/BP]. ("MONO" will light up.)

Sound will be produced in monaural, but this also reduces noise.

Press the button again to cancel. "MONO" will go out.

Normally, you'll want to listen in stereo, so leave "MONO" off. This way, you can listen to stereo broadcasts in stereo, and monaural broadcasts in mono.

You can preset an FM station in monaural by following the steps under "Presetting only your favorite stations" on page 12. After selecting the station in step 1, select "MONO" with [◀◀/▶▶, FM MODE/BP], then continue with steps 2 and 3.

### Notes

- If you preset stations in memory they can be easily selected from the remote control with [◀/V], [▶/∧/∨] or the numeric buttons.
  1. Press [TUNER] to select the band.
  2. Press [◀/V] or [▶/∧/∨] to select the channel, or select the required channel directly with the numeric buttons.  
To select a two-digit channel:  
Press [≥10] and then the two numbers you want within 10 seconds or so.
- Sound is momentarily interrupted if you load/unload tapes while listening to an AM broadcast.

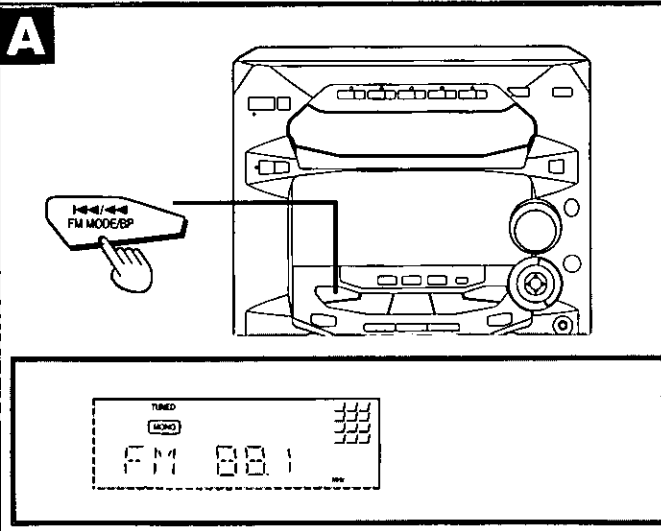

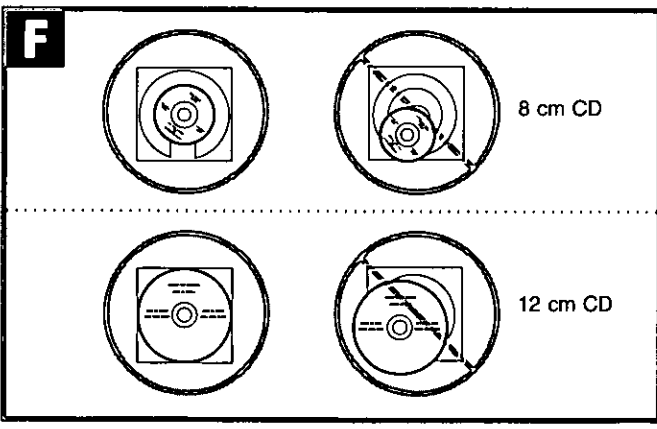
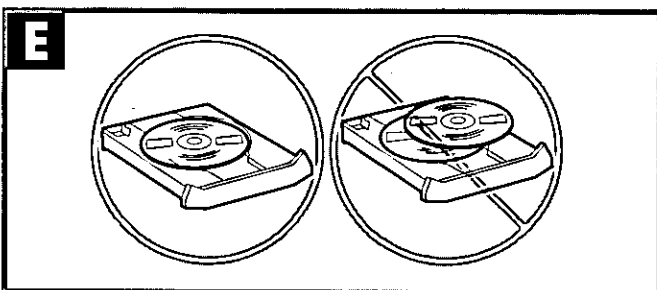
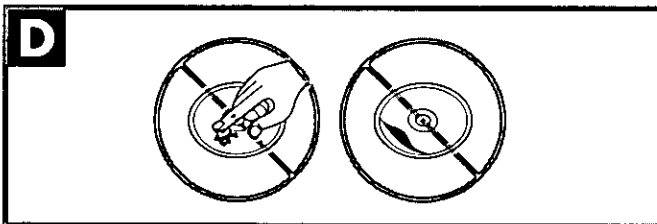
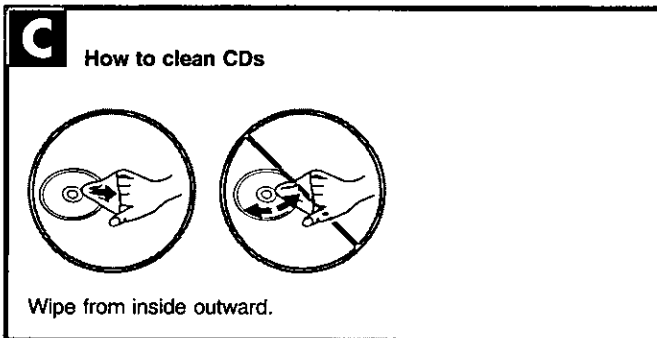
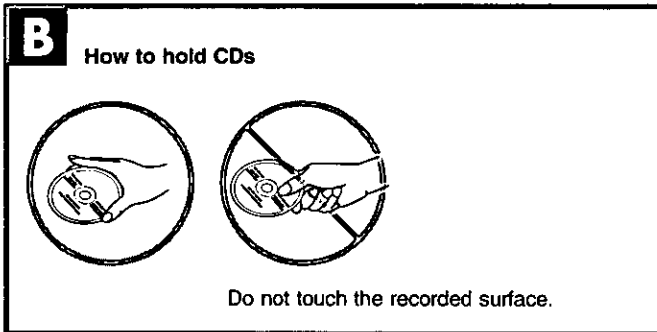
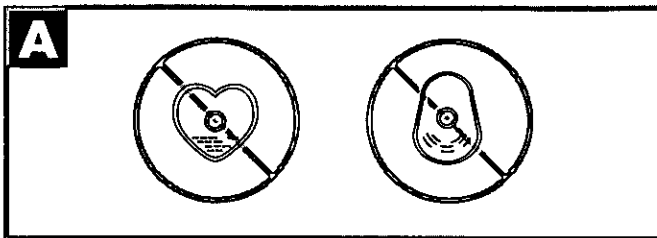

## Concerning compact discs

With this system, you can only play CDs having this mark.

However, do not use irregular shaped CDs. CDs of the sort can damage the unit. **A**



## Handling precautions **B ~ D**

- If you are taking the CD from a cold to a warm environment, moisture may form on the CD. Wipe this off with a soft, dry, lint-free cloth before using the CD.
- Do not write on the label side with a ball-point pen or other writing instrument.
- Do not use record cleaning sprays, benzene, thinner, static electricity prevention liquids or any other solvent.
- Do not attach labels or stickers to CDs. (Do not use CDs with exposed adhesive from tape or left over peeled off stickers.)
- Do not use scratch-proof protectors or covers other than those specified for use with this system.
- Do not use CDs printed with label printers available on the market.

## Storage precautions

Be sure to store CDs in their cases to protect them from dust, scratches, and warping.

### Do not place or store CDs in the following places

- Locations exposed to direct sunlight
- Humid or dusty locations
- Locations directly exposed to a heat vent or heating appliance
- In the glove compartment or on the rear deck of an automobile

## To prevent damage

Always observe the following points.

- Load only 1 CD on the tray. **E**
- Load CDs as shown in figure **F**.  
The adapter is not needed with 8 cm CDs (singles).
- Set the system on a flat, level surface.  
Do not set it on top of magazines, inclined surfaces, etc.
- Do not move the system while tray is opening/closing, or when loaded.  
Always unload all CDs before moving the system.
- Do not put anything except CD in tray.
- Do not use cleaning CDs or CDs which are badly warped or cracked.
- Do not disconnect the power cord from the household AC outlet during disc changing operation.

## Listening to compact discs

Always stop the changer before loading or changing CDs. You cannot change CDs while a disc is playing.

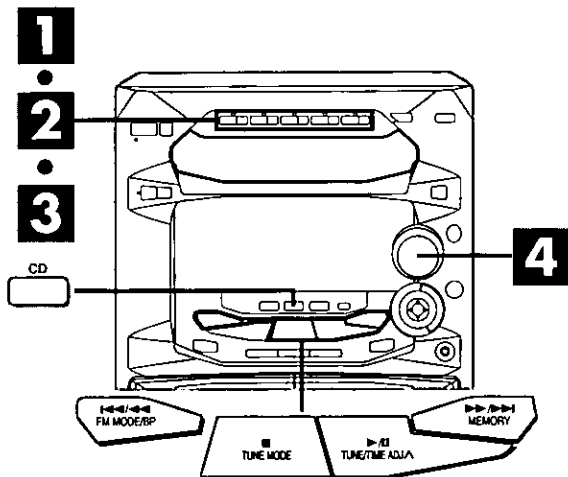

**1** Press a [▲] button.  
The unit will come on automatically and the tray opens.

**2** Set CD in the tray.  
To continue loading CDs in the other trays  
Press another [▲] button to open the required tray.  
The current tray closes and the selected tray automatically opens.  
Press the same [▲] to close the tray.

**3** Press [(CD 1) ~ (CD 5)] to play your desired disc.  
(If the desired CD is indicated on the display panel, the same operation can be accomplished by pressing [▶/||].)  
Play will start from the first track on the disc and will continue until the last track of the final disc is played (see below).

**4** Adjust the volume level.

To stop the disc play **A**  
Press [■].

When "▶" appears on the display **B**  
It indicates there are 13 or more tracks on the disc in the playing position.

**Disc indicators**  
The disc indicators light whenever the tray is in the playing position whether it is loaded or not.

**What is meant by "final disc"?**  
For example, if play starts from disc 4, disc 3 will be the "final disc".  
**Order of progression:**  
Disc 4→5→1→2→3

**One touch play**  
If the unit is in standby mode and a CD is loaded, press [CD] or [(CD 1) ~ (CD 5)].  
The unit will come on automatically and play will start.

|  |  |
|--|--|
| <b>To pause</b>                            | Press [▶/  ] during playback.<br>To resume playback, press [▶/  ].               |
| <b>To search forward/backward (Search)</b> | Hold down [◀◀/▶▶] (backward) or [▶▶/▶▶] (forward) during playback or pause mode. |
| <b>To skip forward/backward</b>            | Press [◀◀/▶▶] (backward) or [▶▶/▶▶] (forward) during playback or pause mode.     |

### Notes

- During random play (page 16), you cannot skip to tracks which have already been played.
- During program play (page 17) or random play, you can search forward or backward only within the current track.
- During program play, skipping is always in the programmed order, whether forward or backward.

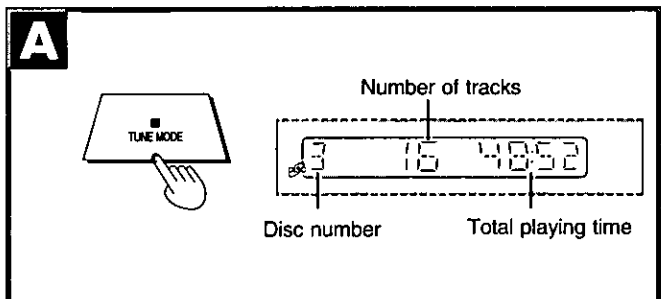
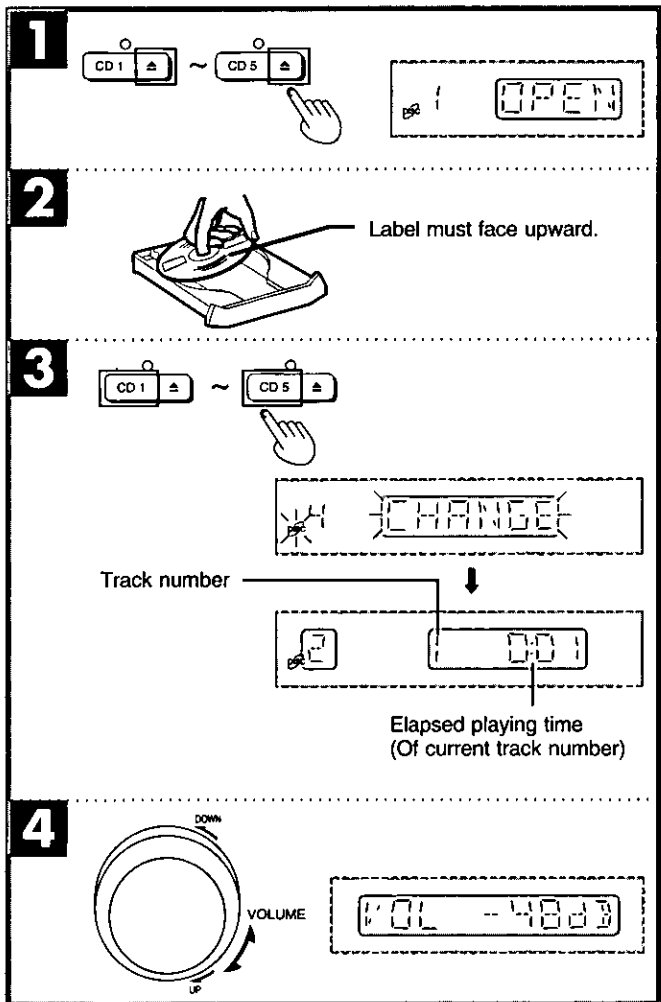

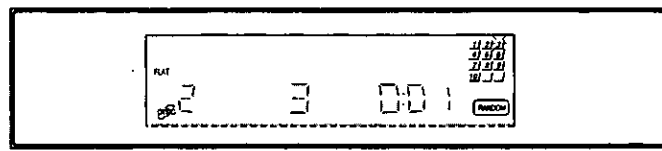
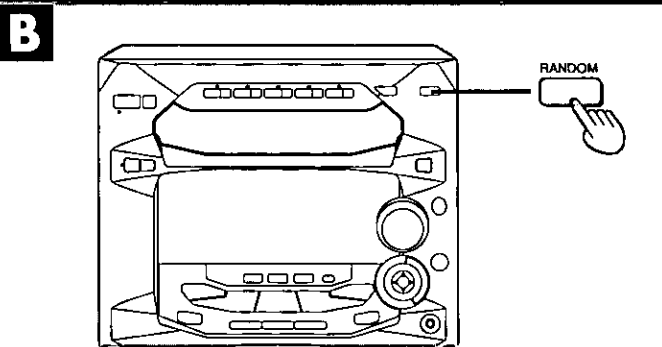
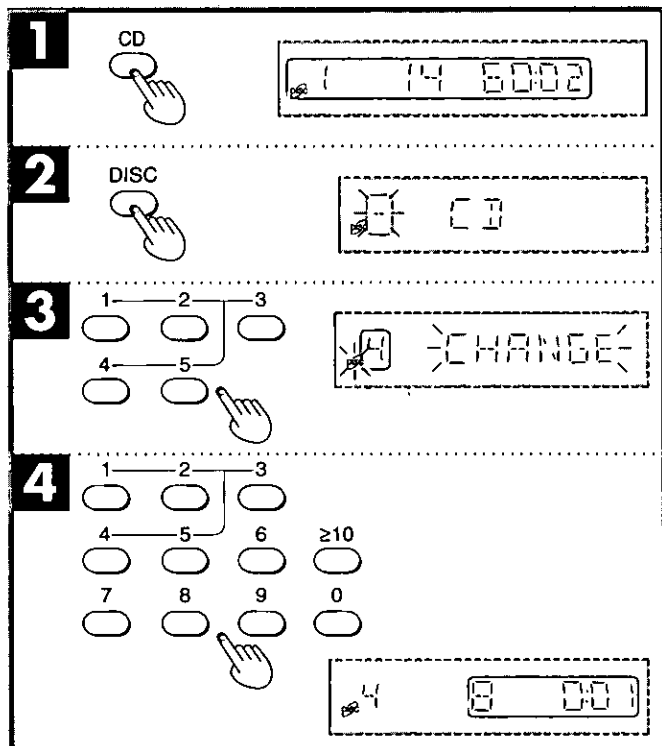
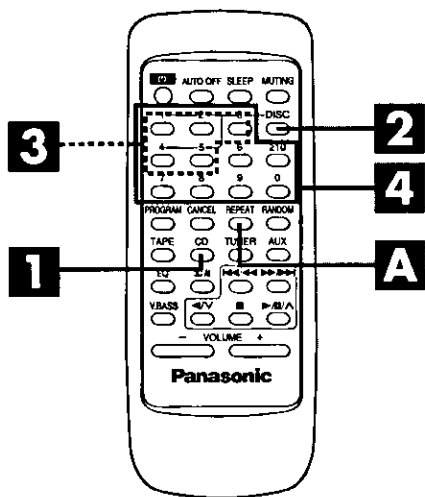

## Listening to compact discs

### Direct access play

by remote control only

- 1** Press [CD].
- 2** Press [DISC].
- 3** (within 10 seconds or so)  
Press [1] – [5] to select the disc you want.
- 4** Press the numeric button to select the desired track number.  
The CD will be played from the selected track to the last track of the final disc (page 15).

#### To select a two-digit track

Press [≥10] and then the two numbers you want within 10 seconds or so.

#### For example

Track no. 20: [≥10] → [2] → [0]

Track no. 35: [≥10] → [3] → [5]

### Repeat play

by remote control only

Press [REPEAT] before or during play. **A**

All tracks on the loaded CDs are repeated.

#### To cancel repeat play

Press [REPEAT] once again.

#### To repeat your favorite tracks

1. Program the tracks you want (perform steps **1** ~ **6** on page 17).
2. Press [REPEAT] and make sure "CD" is displayed.
3. Press [▶/||/△]. Playback will start.

#### To repeat just one track

Set the 1-TRACK mode (page 18), press [REPEAT] before or during playback, and make sure "CD" is displayed.

### Random play

Press [RANDOM]. **B**

Every time you press the button:

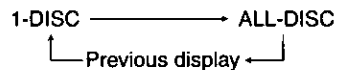

#### To random play just one disc

Select the CD you want to random play with [(CD 1) ~ (CD 5)] and press [RANDOM] to select "1-DISC".

#### To random play all the loaded CDs

Press [RANDOM] to select "ALL-DISC".

All tracks on the CD(s) will be played in random order. Playback will stop automatically when all tracks have been played.

#### To cancel random play

Press [RANDOM] to clear "RANDOM" display.

#### Note

You can use random play with your program. Only the programmed tracks will be played, but in random order.



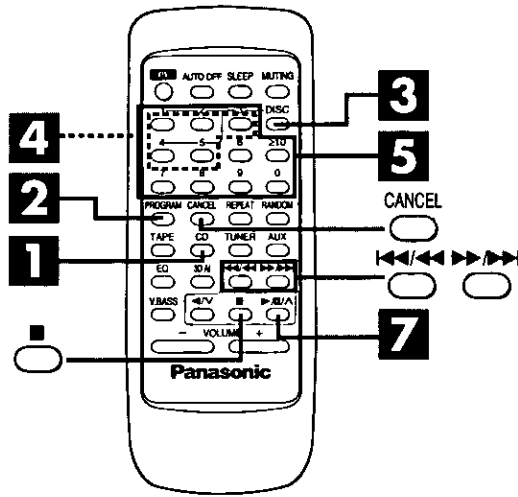

**Program play**

**by remote control only**

You can program up to 24 tracks.

- 1** Press [CD].  
Ensure CD is stopped.
- 2** Press [PROGRAM].
- 3** Press [DISC].
- 4** (within 10 seconds or so)  
Press [1] – [5] to select the disc you want.
- 5** Press the numeric button to select the desired track.
- 6** Repeat steps **3** through **5** until you have programmed all the tracks you want.
- 7** Press [▶/||/▲].  
Play will start in the programmed sequence.

**To cancel program play mode**

Press [PROGRAM] in the stop mode.

Programmed contents will be saved in memory.

Pressing [■] will cancel program play, but it will also erase the entire program.

**To select a two-digit track**

Press [≥10] and then the two numbers you want.

**When "CD FULL" appears **A****

The number of programmed tracks is limited to 24. No further tracks can be programmed.

**You can do the following during program mode **B****

- Check program contents.  
Press [◀◀/▶▶] or [▶▶/▶▶].  
Every time you press one of the buttons, the track and program No. are shown on the display.
- Add to the program.  
Repeat steps **3** through **5**.
- Cancel entries.

|                                |  |
|--------------------------------|--|
| From the last programmed track | Press [CANCEL].  |
| A specified track only         | Select the track with [◀◀/▶▶] or [▶▶/▶▶], and press [CANCEL] within 3 seconds. |
| All tracks                     | Press [■].   |

**Memory retention**

Your program is retained in memory for about 2 weeks while the system is unplugged.

**To replay your program**

If you turned OFF your program with [PROGRAM], you can play it again as explained below.

1. Press [PROGRAM].
2. Press [▶/||/▲].

**If you program a track not on your CDs**

The track is initially programmed, but during program play, the player will skip that track and will continue playing from the next programmed item.

**1**

**2**

**3**

**4**

**5**

**7**

**A**

**B** Indicates program mode

Compact disc operations

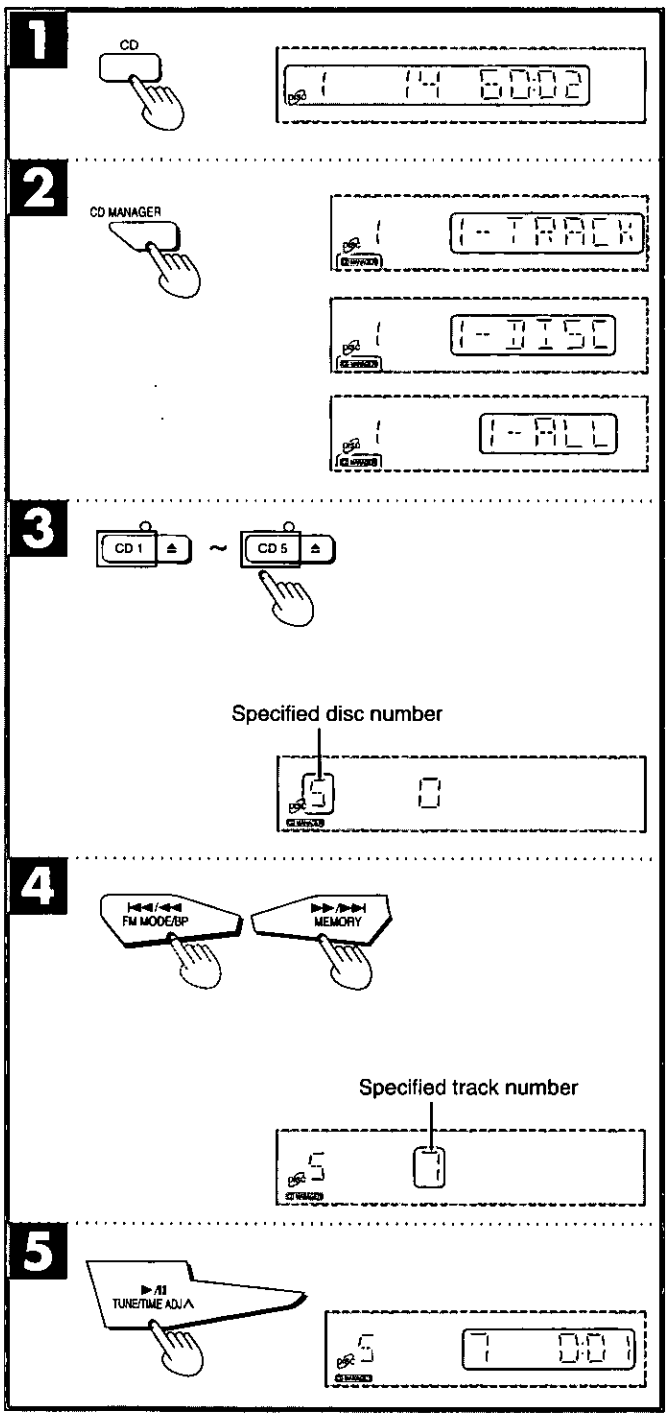
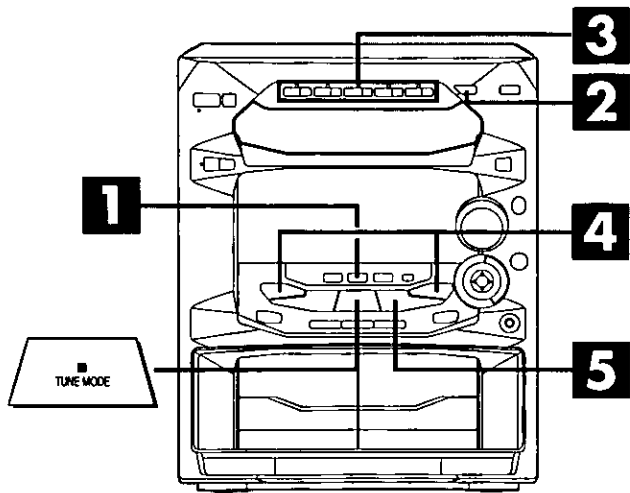

**Listening to compact discs**

**To listen to special CDs and tracks (CD Manager function)**

This function makes it easier for you to select special CDs and tracks from amongst those loaded in the player.

You can use this function to make recordings as well.

**There are 3 CD/track selection modes.**

- For playing back 1 track only from all loaded CDs  
1-Track mode (1-TRACK)
- For playing back 1 CD only from all loaded CDs  
1-Disc mode (1-DISC)
- For playing back 1 track on all loaded CDs  
1-Track All-Disc mode (1-ALL)

**1 Press [CD].**  
Ensure CD is stopped.

**2 Press [CD MANAGER] to select the desired mode.**  
Every time you press the button:

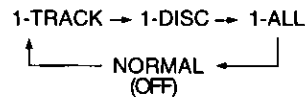

- 1-TRACK: Only one particular track is played.
  - 1-DISC: The tracks on only one particular disc are played.
  - 1-ALL: The same track numbers on each of the CDs are played in succession.
- (NORMAL: The original display is restored in about 3 seconds.)

**3 Press [(CD 1) ~ (CD 5)] to select the disc you want.**  
**Note**  
This step is not required if 1-ALL was selected in step 2.

**4 Press [◀◀/▶▶] or [▶▶/▶▶] to select the desired track.**  
**Note**  
This step is not required if 1-DISC was selected in step 2.

**5 Press [▶/II].**  
The selected track will start.

**To stop play**  
Press [■].

**When playback ends**  
"NORMAL" will appear on the display for about 3 seconds, then the CD MANAGER function will turn OFF automatically.

**During play in the 1-ALL mode:**

- It is not possible to skip back to a CD whose track has already been played.
- If a CD does not have the designated track number, it is skipped and play continues.

**Notes**

- You can use the CD Manager function together with repeat play.
- CD Manager function will be canceled when you press the [RANDOM] button.

## Listening to tapes

### Types of tapes which can be played correctly:

The unit automatically identifies the type of tape.

|                        |   |
|------------------------|---|
| NORMAL POSITION/TYPE I | ✓ |
| HIGH POSITION/TYPE II  | ✓ |
| METAL POSITION/TYPE IV | ✓ |

You can use either deck 1 or deck 2 for tape playback.

**1** Press [TAPE, DECK 1/2].  
The unit will come on automatically.  
If the unit was off and a cassette was loaded, play will start automatically (One touch play function).

**2** Press [▲ DECK 1 OPEN] or [▲ DECK 2 OPEN] and insert the tape.  
Insert the tape with the exposed tape facing down.  
Close the holder by hand.

**3** Press [REV MODE] to select the reverse mode.

Every time you press the button:

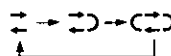

→ : One side is played, then playback stops automatically.

↔ : Both sides (front side → reverse side) are played one time each, then playback stops automatically.

↻ : Both sides are played 8 times each, then playback stops automatically.

**4** Press [◀] or [▶] to start playback.

[▶]: The forward side (front side) will play.

[◀]: The reverse side will play.

**5** Adjust the volume level.

### To stop tape playback

Press [■].

### To change the deck to be used **A**

Press [TAPE, DECK 1/2] to select the deck you want to use when you load cassettes into both decks.

### To listen to 2 tapes consecutively

Load a tape into each deck and select "↻". Both tapes will be played 8 times each.

### Note

Playback is momentarily interrupted while playing back tapes, if you open the other deck.

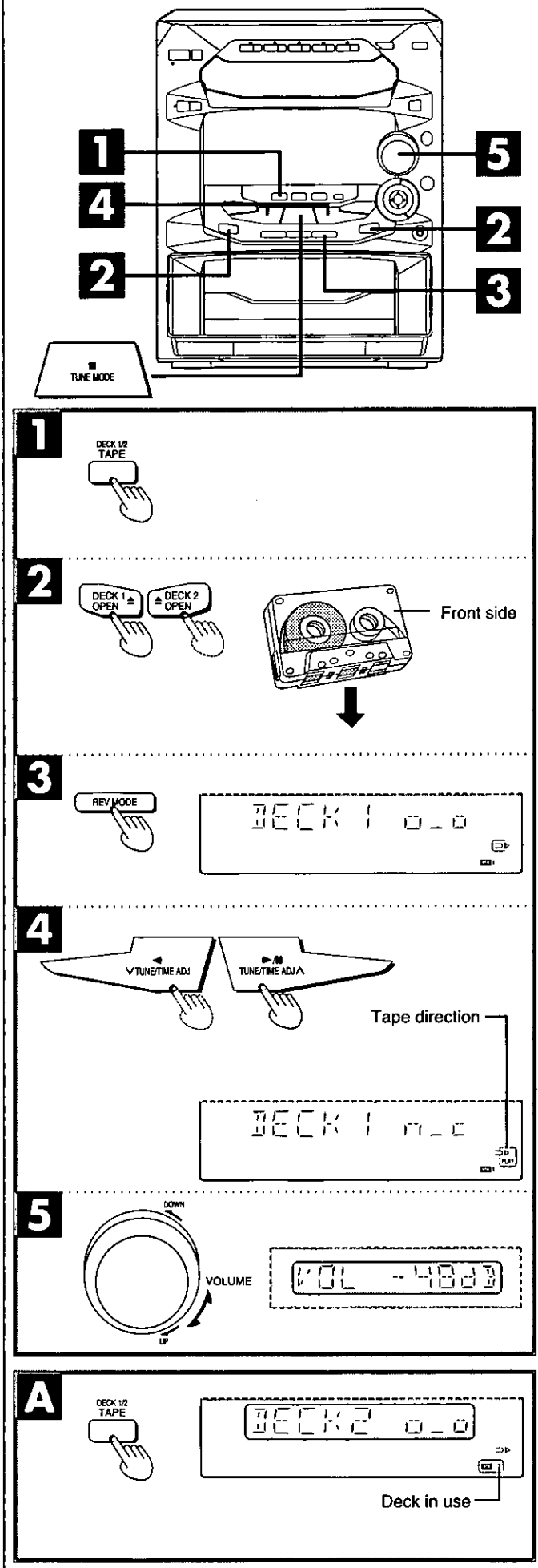

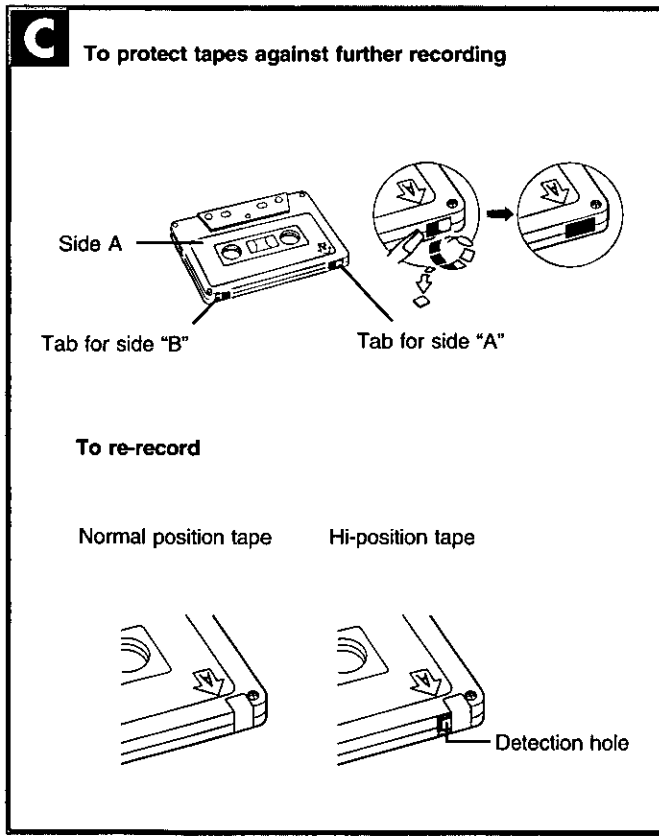
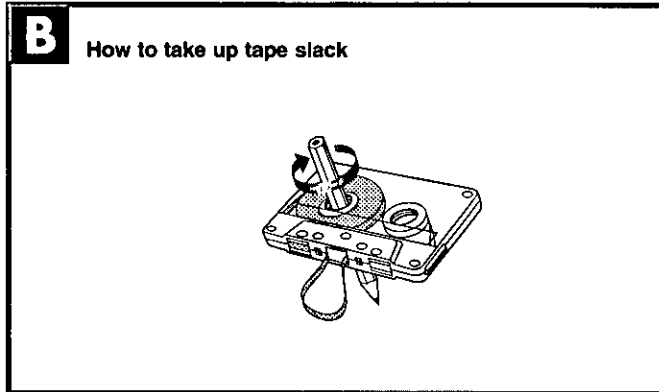
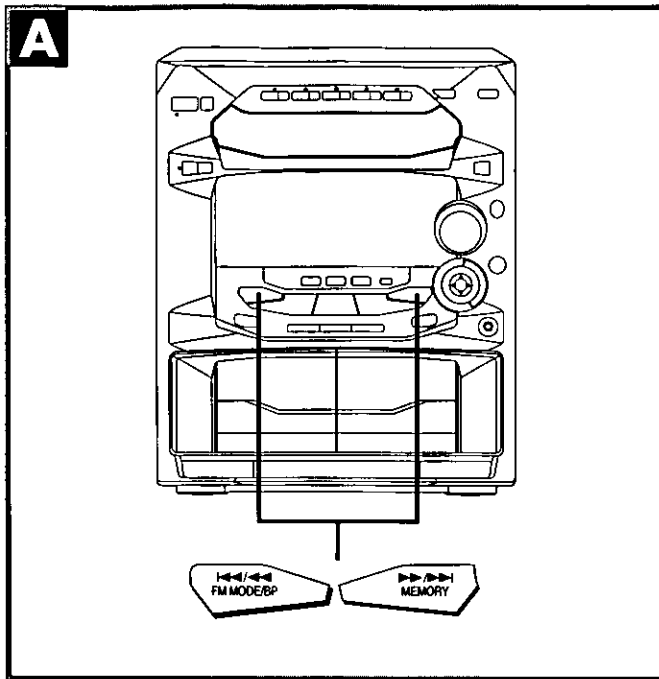

**Listening to tapes**

**To fast-forward or rewind the tape A**

Press [**◀◀/◀◀**] or [**▶▶/▶▶**] in the stop mode.

| Tape direction | To rewind        | To fast-forward  |
|----------------|------------------|------------------|
| "▶"            | [ <b>◀◀/◀◀</b> ] | [ <b>▶▶/▶▶</b> ] |
| "◀"            | [ <b>▶▶/▶▶</b> ] | [ <b>◀◀/◀◀</b> ] |

**To find the beginning of a program (TPS: Tape Program Sensor) A**

TPS finds the beginning of a track and resumes play from there. Each press increases the number of tracks skipped, up to a maximum of 9.

Press [**◀◀/◀◀**] or [**▶▶/▶▶**] during play.

**Notes**

The TPS function searches for silent parts of about 4 seconds in length which are normally found between tunes. As a result, it may not function properly in the following cases:

- With short silent parts
- When noise occurs between tunes
- With silent parts found within tunes

**Concerning cassette tapes**

**Selection of cassette tapes**

Tapes can get caught on the capstans. Use caution with the following types of tapes.

**Cassette tapes exceeding 100 minutes**

Tapes are made of a thin film material. Do not repeatedly advance and stop the tape, fast-forward it or rewind it.

**Endless-tapes**

For this unit, it is recommended to use tapes which are appropriate to the auto reverse mechanism.

Always read the instructions provided with your tapes.

**Tape slack B**

Tape slack may cause the tape to break.

**Erase prevention C**

Use a screwdriver or similar object to break out the tab.

**To re-record on a protected cassette**

Cover the hole with adhesive tape.

Do not cover the detection hole on hi-position tapes.

**Storage precautions**

**Do not place or store tapes in the following places:**

- In high temperature (35°C or higher) or high humidity (80% or higher) areas
- In a strong magnetic field (near a speaker, on top of a TV, etc.) This can erase a recording.
- Locations exposed to direct sunlight

## Before recording (Deck 2 only)

### Types of tapes which can be recorded correctly

The unit automatically identifies the type of tape.

|                        |   |
|------------------------|---|
| NORMAL POSITION/TYPE I | ✓ |
| HIGH POSITION/TYPE II  | ✓ |
| METAL POSITION/TYPE IV | × |

Metal position tapes can be used, but the unit will not be able to record or erase them correctly.

### To record from the beginning of the tape **A**

You cannot record on the leader part of the tape. Before recording, wind the tape past the leader to a point where recording can start immediately.

### How volume, sound quality/field affect recording

The tape you are recording is not affected whatsoever by changes in volume, sound quality/field.

### To erase a recorded sound

1. Press [TAPE, DECK 1/2].
2. Insert the recorded tape into deck 2.
3. Press [REV MODE] to select reverse mode.
4. Press [● REC/STOP].

#### Notes

- You cannot open deck 1 while recording.
- You cannot fast-forward or rewind one deck while recording with the other.

## Tape-to-tape recording

The recording level will be recorded as it is on the tape being played back.

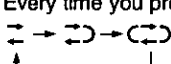
- 1 Press [TAPE, DECK 1/2].
- 2 Press [△ OPEN] on both decks and insert the tapes.  
For playback: Into deck 1  
For recording: Into deck 2  
Close the holders by hand.  
Tape direction is automatically set to "▷".
- 3 Press [REV MODE] to select the reverse mode.  
Every time you press the button:  

  - ▷ : One side is recorded, then recording stops automatically.
  - ▷◁, ◁▷ : Both sides (front side → reverse side) are recorded, then recording stops automatically.
- 4 Press [TAPE EDIT] to start recording.  
• If you selected "▷◁" in step 3, the direction will automatically change to "▷◁" when recording starts.

#### To stop recording

Press [■].  
Both decks will stop.

#### To start recording on the reverse side

Load a tape and change the tape direction as follows:

1. Press [TAPE, DECK 1/2] and select tape deck 2.
2. Press [◀] and immediately thereafter [■]. The tape direction will be shown as "◁".

#### To record from a specific point on a tape

Before recording, advance the tape to the point from where you want to start recording.

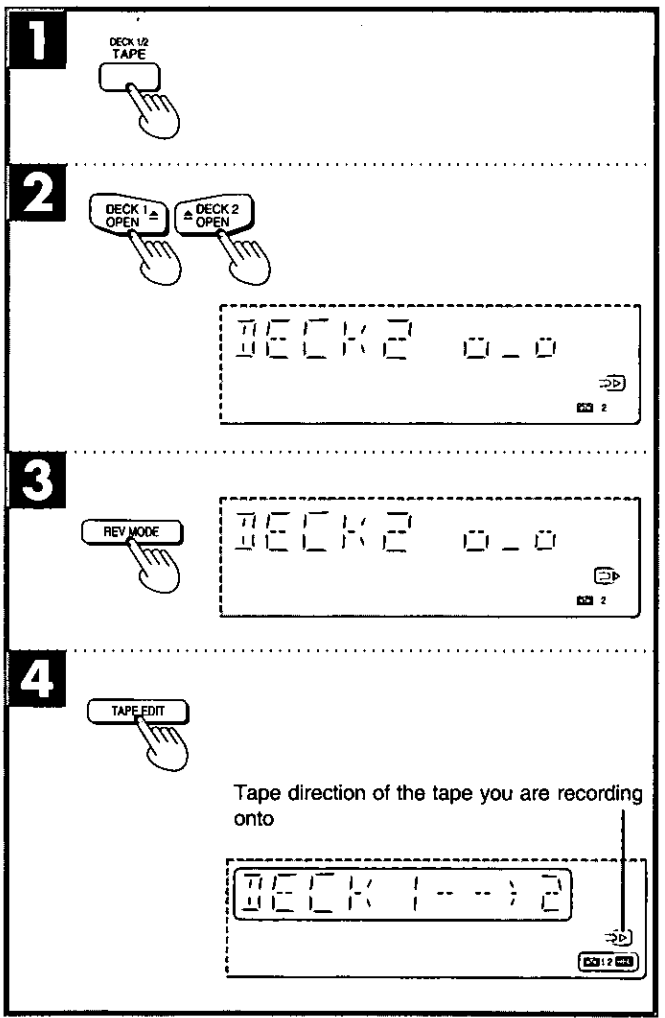
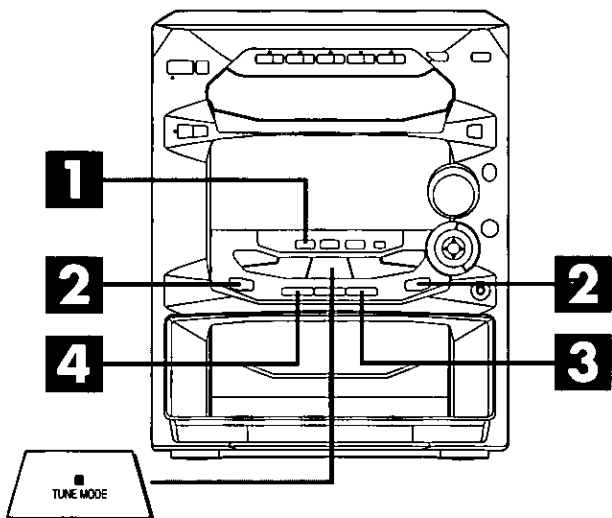
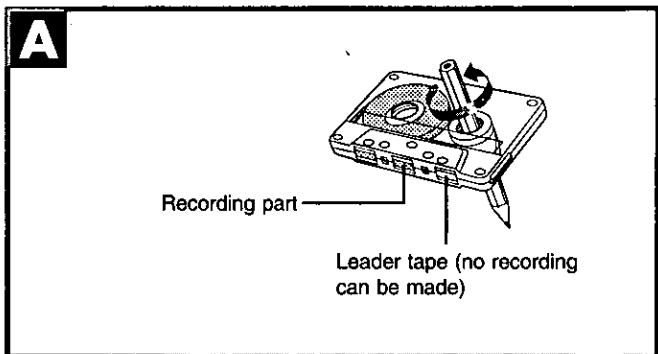

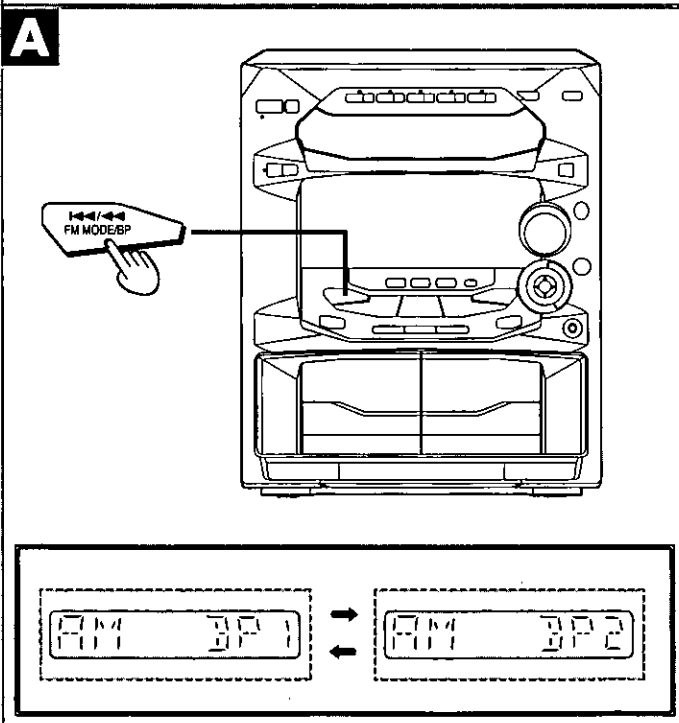
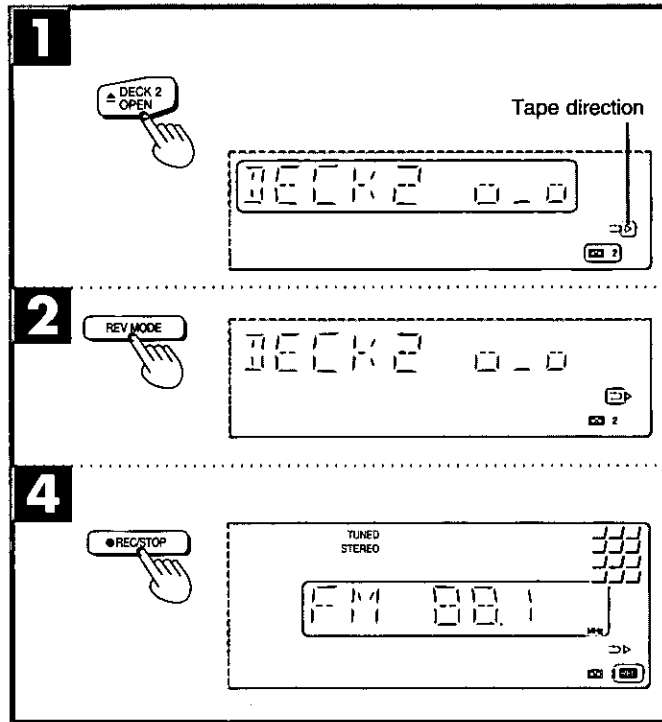
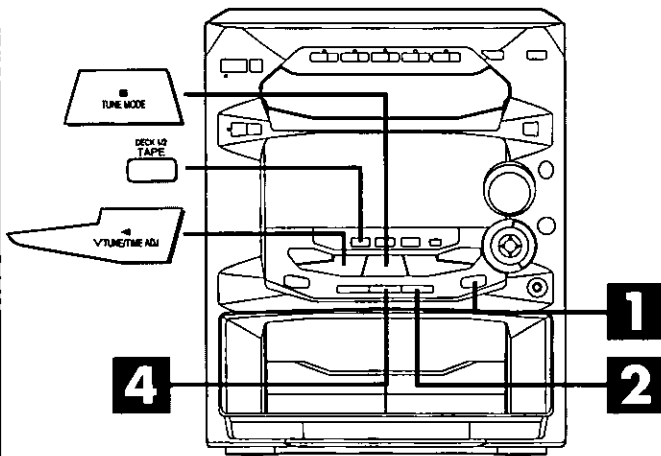

## Recording from radio broadcasts

- 1** Press [**DECK 2 OPEN**] and insert the tape.  
Close the holder by hand.  
Tape direction is automatically set to "▷".
- 2** Press [**REV MODE**] to select the reverse mode.  
Every time you press the button:
  - ▷ → ◁ → ▷ → ◁ : One side is recorded, then recording stops automatically.
  - ▷ → ◁ → ▷ : Both sides (front side → reverse side) are recorded, then recording stops automatically.
- 3** Select a radio station. Perform steps **1** through **3** on page 13.
- 4** Press [**REC/STOP**] to start recording.  
If you selected "▷ → ◁" in step **2**, the direction will automatically change to "▷ → ◁" when recording starts.

### To stop recording

Press [**REC/STOP**] again.  
Recording can also be stopped by pressing [**STOP**].

### To start recording on the reverse side

Load a tape and change the tape direction as follows:

1. Press [**TAPE, DECK 1/2**] and select tape deck 2.
2. Press [**◁**] and immediately thereafter [**REC/STOP**]. The tape direction will be shown as "◁".

### To record from a specific point on a tape

Before recording, advance the tape to the point from where you want to start recording.

### To cut an unnecessary part while recording

1. Press [**REC/STOP**] during the unnecessary part. The cassette deck will go into the stop mode.
2. Press [**REC/STOP**] to resume recording again. Recording will continue in the same direction as before.

### Note

When recording an AM broadcast, sound is momentarily interrupted when you start and stop the recording.

### To reduce noise while AM recording (Beat proof function) **A**

Press [**FM MODE/BP**] while recording.

Each time you press the button, "BP1" and "BP2" will be displayed alternately.

Select the position where there is less noise.

## Recording from compact discs

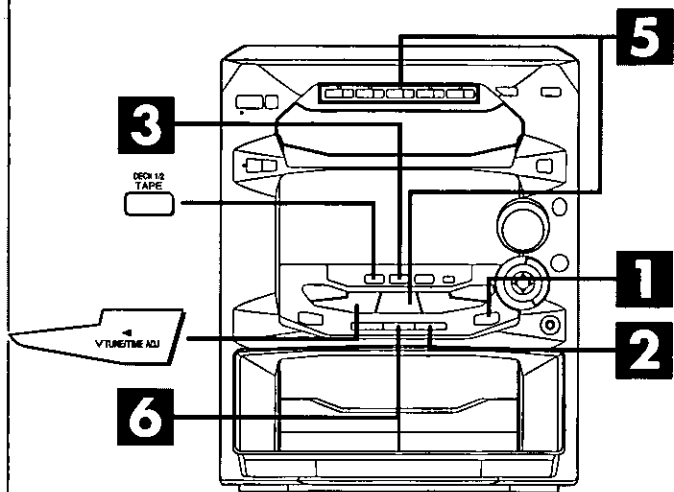

### 1 Press [DECK 2 OPEN], and insert the tape.

Close the holder by hand.  
Tape direction is automatically set to "▷".

### 2 Press [REV MODE] to select the reverse mode.

Every time you press the button:

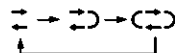

▷ : One side is recorded, then recording stops automatically.

▷, ◁ : Both sides (front side → reverse side) are recorded, then recording stops automatically.

### 3 Press [CD].

### 4 Insert CD in the tray.

(Perform steps 1 ~ 2 on page 15).

### 5 Press [(CD 1) ~ (CD 5)] to select the disc you want.

Pressing [P] will stop playback.

### 6 Press [● REC/STOP] to start recording.

- If you selected "◁, ▷" in step 2, the direction will automatically change to "▷" when recording starts.
- The recording will proceed from the first track on the selected CD and will continue on through the last track of the final disc (page 15).
- The tape deck stops automatically when the CD is finished.

#### To stop recording

- To add a 4 second silent interval before stopping Press [P]. The CD will stop automatically too.
- To stop recording without a silent interval Press [● REC/STOP]. The CD will stop automatically too.

#### To start recording on the reverse side

Load a tape and change the tape direction as follows:

1. Press [TAPE, DECK 1/2] and select tape deck 2.
2. Press [◁] and immediately thereafter [P]. The tape direction will be shown as "◁".

#### To record from a specific point on a tape

Before recording, advance the tape to the point from where you want to start recording.

#### To record programmed tracks

1. After step 4, program the track you want (perform steps 2~6 on page 17).
2. Press [● REC/STOP] to start recording.

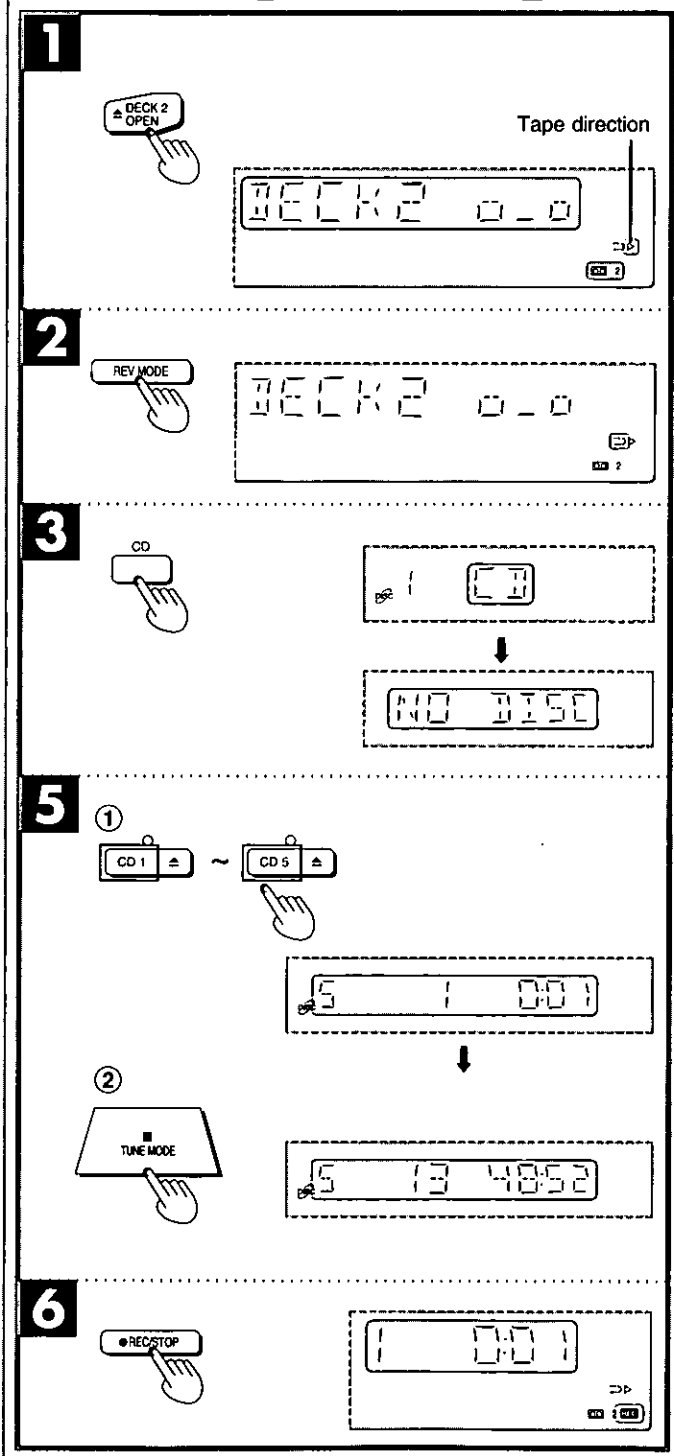

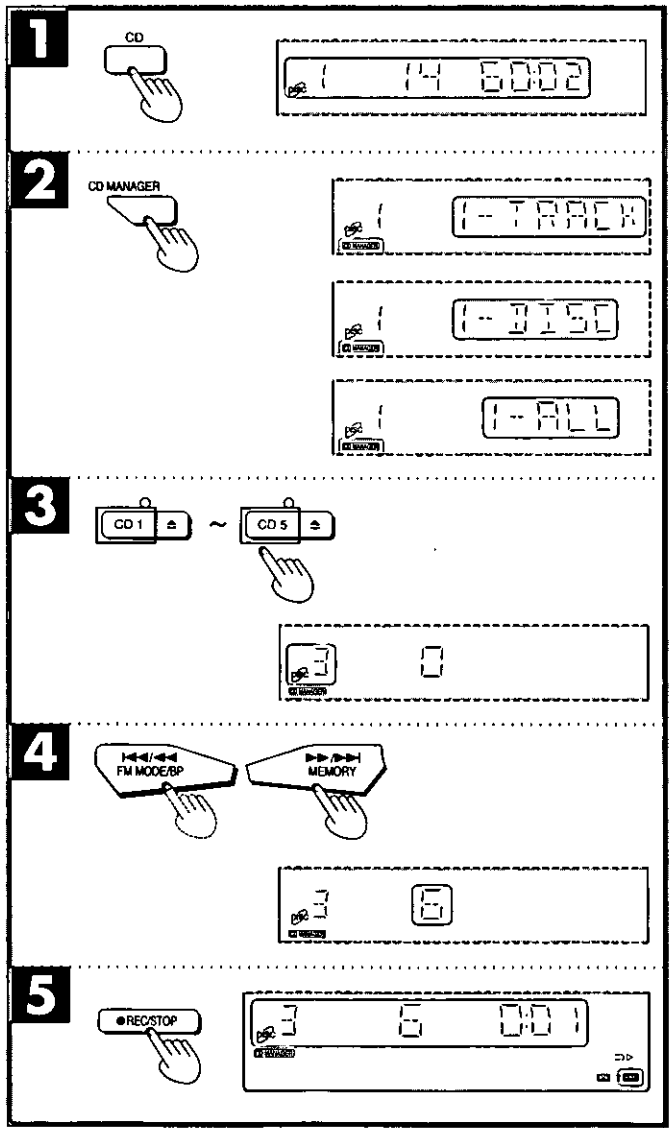
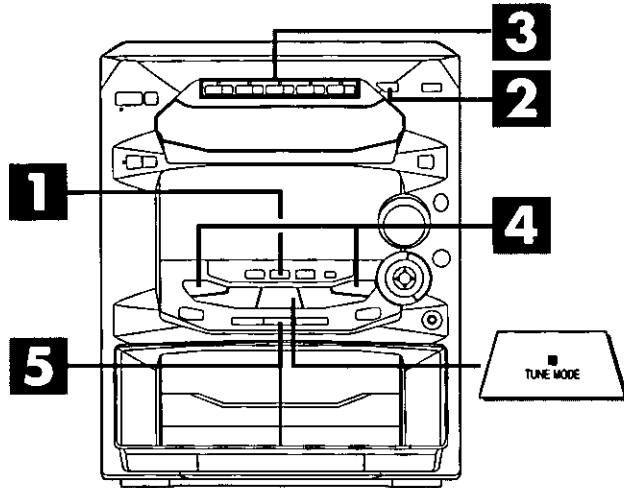
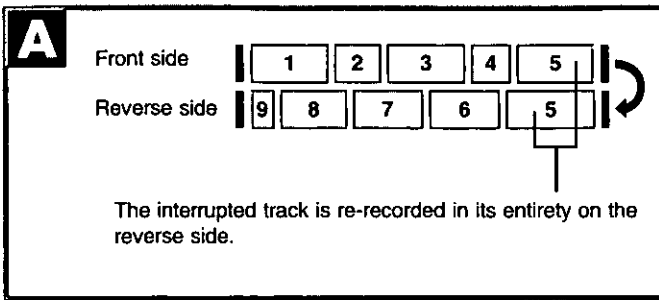

## Recording from compact discs

### To record special CDs and tracks (CD Manager function)

This function makes it easier for you to select special CDs and tracks from amongst those loaded in the player.

- While recording, if a track is cut off in the middle at the end of the front side, it is re-recorded from the beginning, on the reverse side. **A**
- At the end of the reverse side recording stops and the current track will be interrupted.

#### Before recording

Prepare the tape you want to use. Perform step **1** on page 23.

**1** Press [CD].

**2** Press [CD MANAGER] to select the desired mode.

Every time you press the button:

1-TRACK → 1-DISC → 1-ALL



1-TRACK: Only one particular track is recorded.

1-DISC: The tracks on only one particular disc are recorded.

1-ALL: The same track numbers on each of the CDs are recorded in succession.

(NORMAL: The original display is restored in about 3 seconds.)

**3** Press [(CD 1) ~ (CD 5)] to select the disc you want.

**Note**

This step is not required if 1-ALL was selected in step **2**.

**4** Press [◀◀/▶▶] or [▶▶/▶▶] to select the desired track.

**Note**

This step is not required if 1-DISC was selected in step **2**.

**5** Press [● REC/STOP] to start recording.

#### To stop recording

- To add a 4 second silent interval before stopping Press [■]. The CD will stop automatically too.
- To stop recording without a silent interval Press [● REC/STOP]. The CD will stop automatically too.

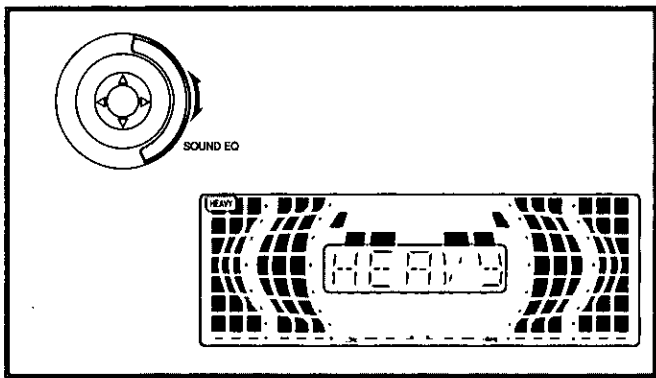
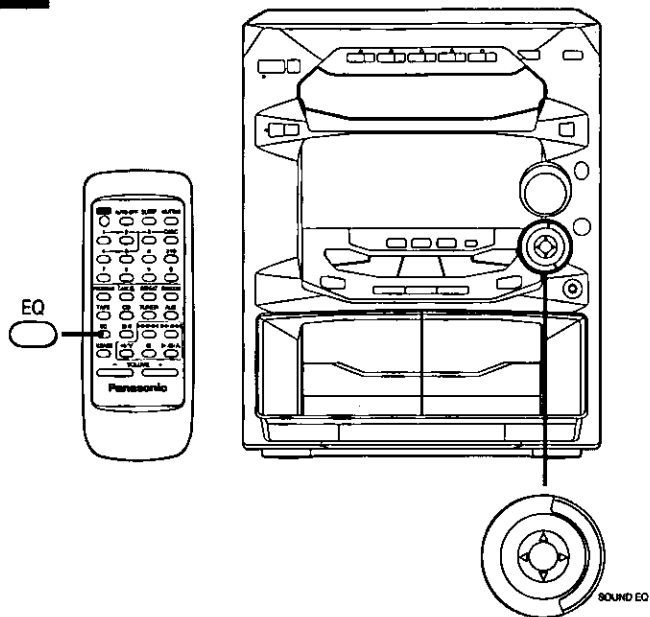
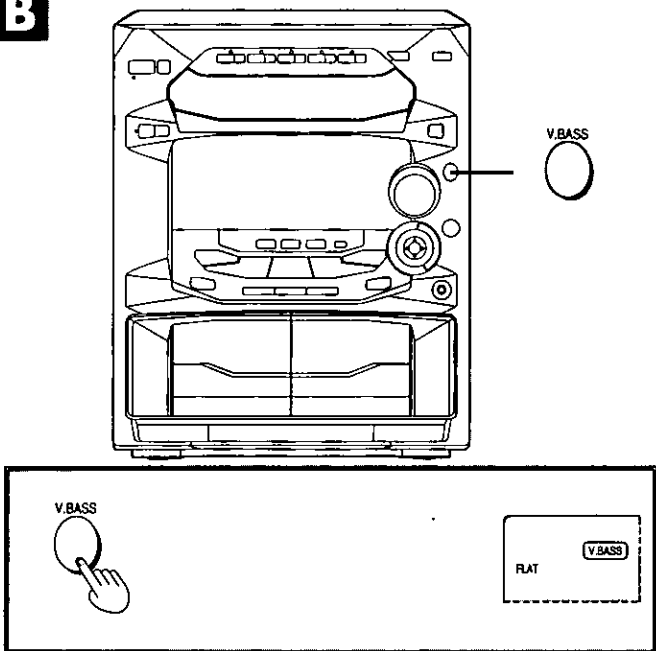

**A****B**

## Using the built-in sound quality/ sound field settings **A**

Dial [SOUND EQ] to select the sound quality or sound field. When it is turned clockwise, the settings are selected in the following sequence.

- ① **HEAVY (sound quality)**  
Select this when playing rock or other kinds of music that sound better with an added punch.
- ② **CLEAR (sound quality)**  
Select this for jazz or other kinds of music for which clarity in the treble range is desired.
- ③ **SOFT (sound quality)**  
Select this when listening to background music.
- ④ **DISCO (sound field)**  
Select this to produce sound with the same kind of lengthy reverberations heard at a disco.
- ⑤ **LIVE (sound field)**  
Select this to make vocals more alive.
- ⑥ **HALL (sound field)**  
Select this to add an expansiveness to the sound to produce the atmosphere of a great concert hall.
- ⑦ **MANUAL (see page 26)**
- ⑧ **AI-EQ (see page 26)**

The original display is restored on the display panel in about 5 seconds.

### To release the equalizer

Dial [SOUND EQ] to display "FLAT".

When using the remote control to perform the operations described above

Press [EQ].

Each time this button is pressed, the setting is changed in the sequence described above.

### Note

All recordings are performed at the flat setting even if an alternative sound quality/sound field setting has been selected.

## Adding bass **B**

Press [V.BASS].

Press the button again to cancel.

"V.BASS" goes out.

### Note

You cannot record V.BASS effect, but you can use it for playback sound.

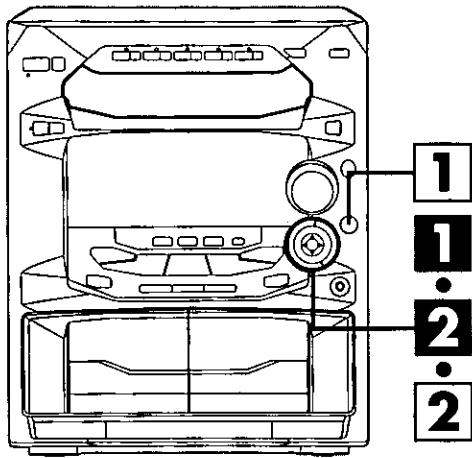

## Varying the sound quality with the manual equalizer

**1** Dial [SOUND EQ] to display "MANUAL".  
When it is turned clockwise, the settings are selected in the following sequence.

- ① HEAVY
- ② CLEAR
- ③ SOFT
- ④ DISCO
- ⑤ LIVE
- ⑥ HALL
- ⑦ MANUAL
- ⑧ AI-EQ
- ⑨ FLAT

**2** Adjust the sound quality.

① ← → direction: For selecting the range of the sound to be adjusted

### Characteristics of each sound range

- Under 100 Hz: Super woofer range
- Around 330 Hz: Bass to midrange
- Around 1 kHz: Midrange
- Around 3.3 kHz: Midrange to treble
- Above 10 kHz: Treble

② ↓ ↑ direction: For adjusting the level (7 steps)

When the level is in the center, the dot flashes rapidly.  
Repeat steps ① and ② to set the desired sound quality.  
The original display is restored on the display panel in about 5 seconds.

To release the equalizer  
Dial [SOUND EQ] to display "FLAT".

### Notes

- The sound quality setting is stored automatically. It is recalled when "MANUAL" is next selected.
- All recordings are performed at the flat setting even if an alternative sound quality setting has been selected.

## Varying the sound quality with the acoustic image (AI) equalizer

The AI equalizer uses the SOFT, SHARP, HEAVY and LIGHT sound quality coordinates to achieve subtle sound quality settings with ease.

**1** Press [3D AI EQ] to adjust the surround level.  
Every time you press the button:

3D AI 1 → 3D AI 2  
↓ AI-EQ (Light off) ↓

**2** Adjust the sound quality.

- ① ← → direction: SOFT-SHARP setting
  - ② ↓ ↑ direction: LIGHT-HEAVY setting
- Repeat steps ① and ② to set the desired sound quality.  
The original display is restored on the display panel in about 5 seconds.

To release the equalizer  
Dial [SOUND EQ] to display "FLAT".

### Notes

- The sound quality setting is stored automatically. It is recalled when "AI-EQ" is next selected.
- All recordings are performed at the flat setting even if an alternative sound quality setting has been selected.

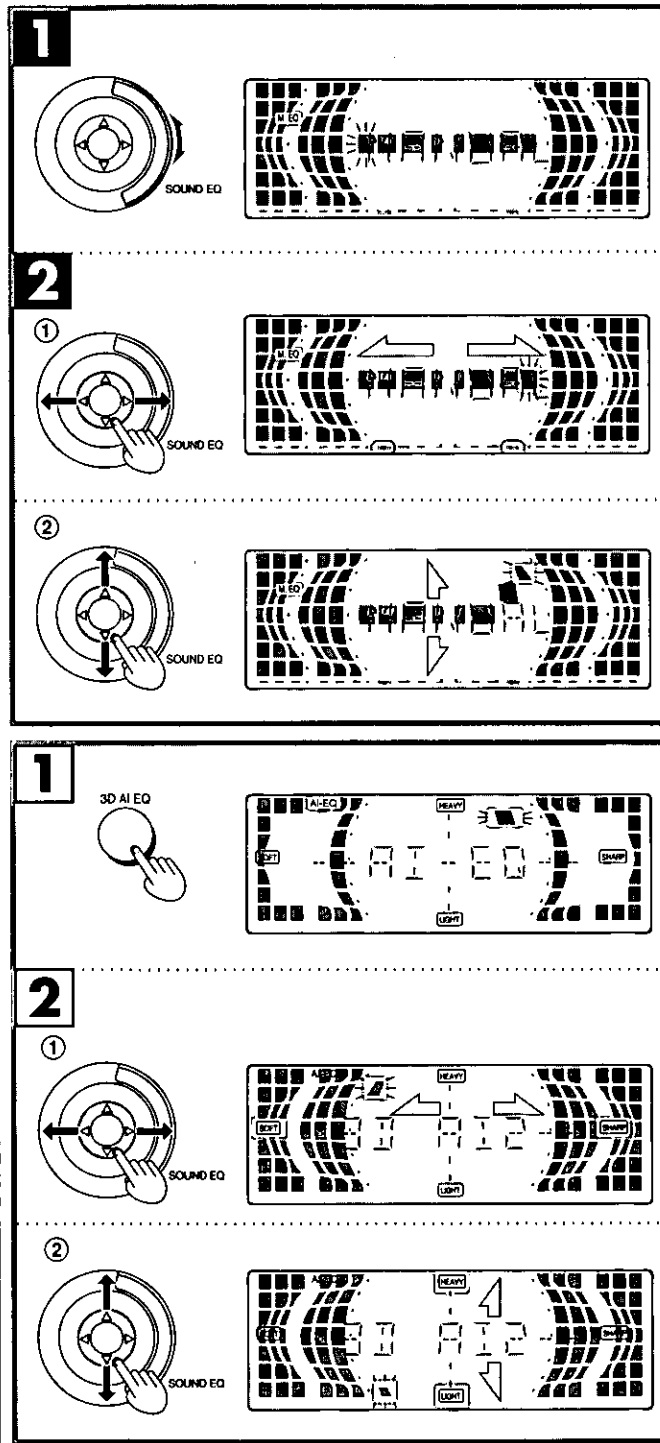

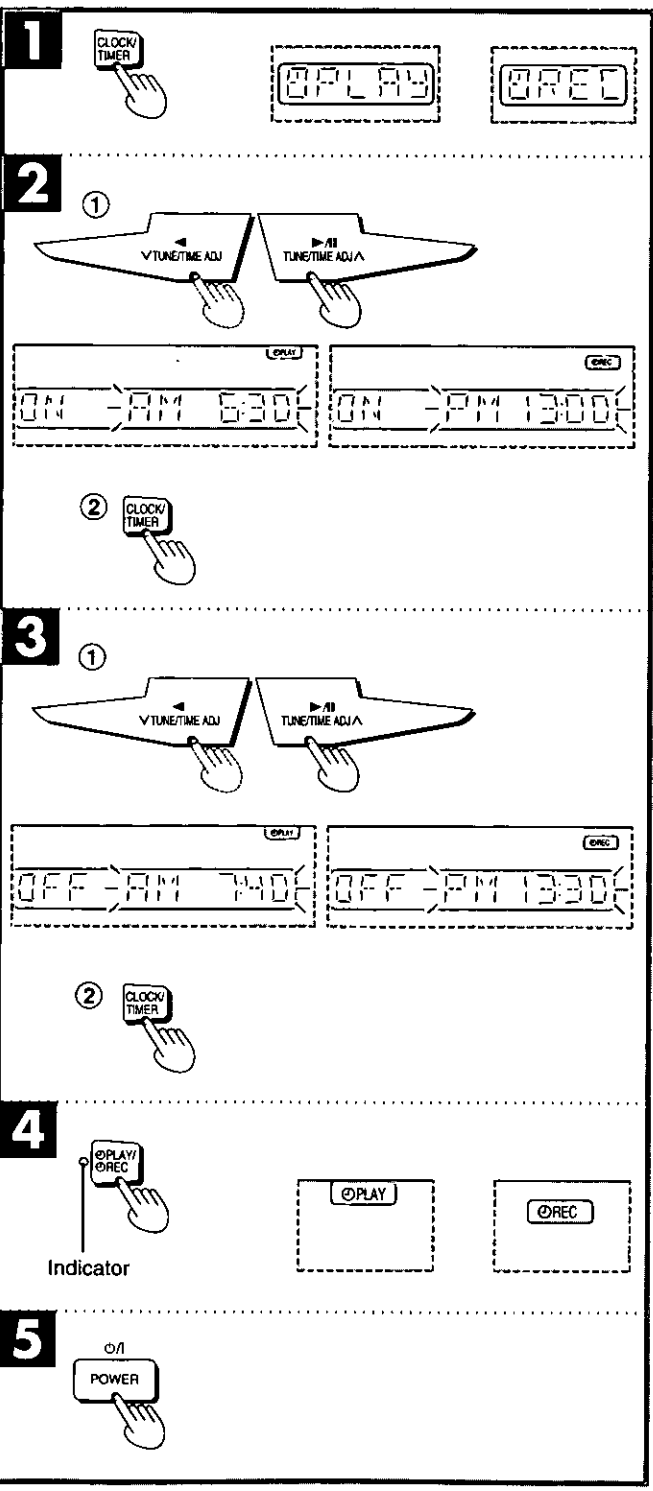
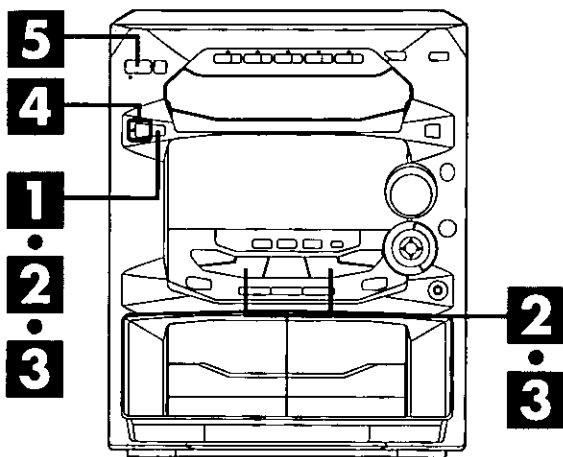

## Using the timer

### Using the play/record timer

The timer has two functions. It can be set to on at a certain time to wake you up, or it can be set to record the radio or from the aux source.

The play timer cannot be used in combination with the record timer.

#### Preparations

- Turn the unit on and set the clock (⇒ page 11).
- **For the play timer**, prepare the music source you want to listen to; tape, CD, radio or aux, and set the volume.
- **For the record timer**, check the cassette's erasure prevention tabs (⇒ page 20: **C**), insert the tape in deck 2, select the reverse mode (⇒ page 22) and tune to the radio station (⇒ page 13) or select the aux source (⇒ page 29).

#### 1 Press [CLOCK/TIMER] to select the timer function.

Every time you press the button:

CLOCK → **⊖**PLAY → **⊖**REC

← Previous display →

**⊖**PLAY : to set the play timer

**⊖**REC : to set the record timer

### Setting the start and finish times

#### 2 (Within 8 seconds or so)

① Press [TUNE/TIME ADJ (∇) or (∧)] to select the starting time.

② Press [CLOCK/TIMER].

#### 3 ① Press [TUNE/TIME ADJ (∇) or (∧)] to select the finishing time.

② Press [CLOCK/TIMER].

The start and finish times are now set.

### Turning the timer on

#### 4 Press [**⊖**PLAY/**⊖**REC].

Every time you press the button:

**⊖**PLAY → **⊖**REC

← (OFF) →

**⊖**PLAY : to turn the play timer on

**⊖**REC : to turn the record timer on

#### 5 Press [**⊖**/I, POWER] to turn the unit off.

The unit must be off for the timers to operate.

##### • For play timer

The timer play will start at the preset time with volume increasing gradually up to the volume level you preset.

##### • For record timer

The record timer comes on about 30 seconds earlier than the set time.

#### To cancel the timer

Press [**⊖**PLAY/**⊖**REC] and check [**⊖**PLAY/**⊖**REC] indicator lights off.

#### To change the settings (when unit is on)

##### • To change the play/record times

Do steps **1**, **2**, **3** and **5**.

##### • To change the source or volume

1. Press [**⊖**PLAY/**⊖**REC] to turn the [**⊖**PLAY/**⊖**REC] indicator off.
2. Make changes to the source or volume.
3. Do steps **4** to **5**.

(Continued on next page)

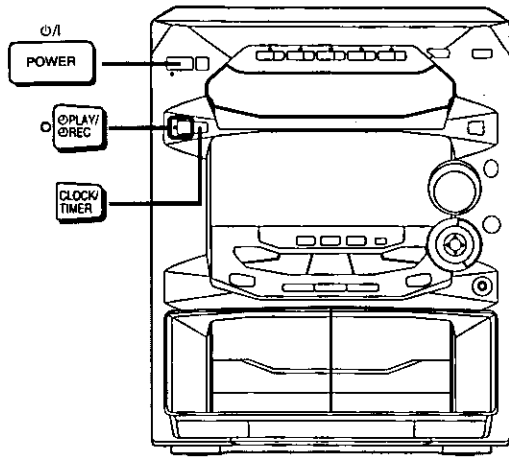

## Using the timer

### Using the play/record timer

#### To check settings

While the unit is on and the "⏻PLAY" (or "⏻REC") indicator is on, press [CLOCK/TIMER] so "⏻PLAY" (or "⏻REC") appears on the display.

Two seconds after "⏻PLAY" (or "⏻REC") appear, the settings are displayed in the following order:

- For play timer
  - ① Play start time
  - ② Play finish time
  - ③ Play source
  - ④ Playback volume
- For record timer
  - ① Recording start time
  - ② Recording finish time
  - ③ Recording source

You can check the settings even when the system is OFF by pressing [CLOCK/TIMER].

#### To enjoy the desired source after the timer setting is completed

The volume level (for play timer) and music source are stored in the timer memory and the timer will start in these preset conditions. However, the Disc numbers and reverse mode do not get stored in the timer memory.

1. After step 5, start playing the desired source.
2. Reset the Disc numbers and reverse mode if you have changed any of them, confirm that a Disc or cassette is inserted, then press [⏻/I, POWER] to put the unit on standby.

#### Turning the timer ON/OFF

One of the timers is on when the [⏻PLAY/⏻REC] indicator is lit. When the unit is on (or off and in NORMAL mode) you can confirm which is on by checking which indicator is on the display.

When the unit is off and in ECO mode, press [CLOCK/TIMER]. The display will then show which timer is on and the settings that have been made (see above).

To change the timer, press [⏻PLAY/⏻REC].

Each time the button is pressed the setting changes as follows.

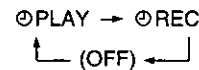

#### Notes

- If you switch the system to the standby mode while the play/record timer is functioning, the OFF time setting will not be activated.
- If AUX is selected as the source, when the timer comes ON, the system will turn ON and will engage "AUX" as the source. If you want to playback or record from a connected component, set the component's timer to the same time. (See the instruction manual that came with the component.)

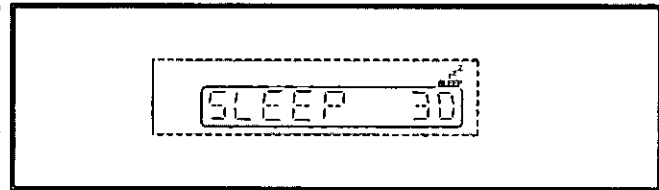
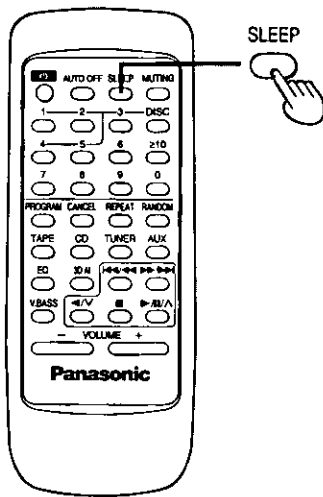
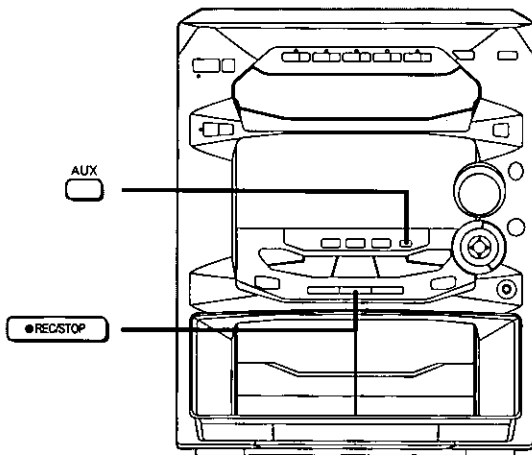
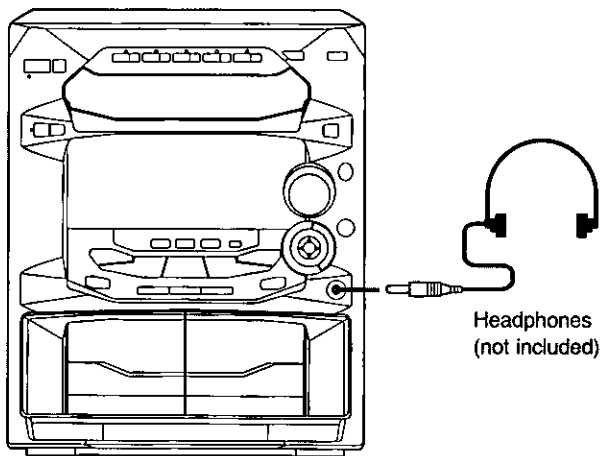
**A****B****C**

## Using the timer

### Using the sleep timer

**A**

This timer turns your system OFF at the set time (Max. 2 hours, settable at 30-minute interval). It lets you fall asleep listening to music.

#### by remote control only

#### Preparation

Switch on the power.

The figure shows how to set the system to standby mode after 30 minutes.

While enjoying the desired source:

Press [SLEEP] to select the desired time.

Every time you press the button:

→ SLEEP 30 → SLEEP 60 → SLEEP 90 → SLEEP 120 → SLEEP OFF

The system is turned off after the set time has elapsed.

#### To cancel the sleep timer:

Press [SLEEP] to select "SLEEP OFF".

#### To confirm the remaining time:

(only while system is ON)

Press [SLEEP].

#### To change the time remaining during operation:

Press [SLEEP] to show the remaining time then press [SLEEP] to select the desired time.

#### Notes

- The sleep timer turns OFF automatically the moment you attempt to edit-record a CD using CD Manager function.
- The sleep timer can be used in combination with the play/record timer.  
The sleep timer always has priority.  
Be sure not to overlap timer settings.

## Using an external unit

### Listening to an external source

(See page 7 for external unit connection)

1. Press [AUX].  
The system will come on automatically.
2. Start playback from the external source. (For details, refer to the owner's manual of the equipment.)

### Recording from an external source

1. Follow steps 1-2 on page 22.
2. Press [AUX].
3. Press [● REC/STOP] (recording starts).
4. Start playback from the external source. (For details, refer to the owner's manual of the equipment.)

### Listening with headphones

Reduce the volume level, and connect the headphones.  
Plug type: 3.5mm (1/8") stereo

#### Note

Avoid listening for prolonged periods of time to prevent hearing damage.

# Troubleshooting guide

Before requesting service for this unit, check the chart below for a possible cause of the problem you are experiencing. Some simple checks or a minor adjustment on your part may eliminate the problem and restore proper operation.

If you are in doubt about some of the check points, or if the remedies indicated in the chart do not solve the problem, refer to the directory of Authorized Service Centers (enclosed with this unit) to locate a convenient service center, or consult your dealer for instructions.

For detailed instructions, contact an authorized servicenter 1-800-211-7262 or web site (<http://www.panasonic.com>).

| Problem | Probable cause(s) | Suggested remedy | Reference page(s) |
|---------|-------------------|------------------|-------------------|
|---------|-------------------|------------------|-------------------|

| Problems common to all systems   |  |  |    |
|--|--|--|----|
| ECO mode is on but the display panel still lights up.                        | DEMO mode is on.   | Turn DEMO mode off.  | 10 |
| The location of the various musical instruments is not well defined.         | The (+) and (-) connections to one of the speakers are reversed.   | Connect the speaker cords correctly.   | 6  |
| The left and right sounds are reversed.                                      | The left and right connections to the speaker are reversed.  | Connect the speaker cords correctly.   | 6  |
| When listening to the external unit, the left and right sounds are reversed. | The left and right connections to the external unit are reversed.  | Connect the external unit's cord correctly.  | 7  |
| There is no sound when a source is being played.                             | The (+) and (-) wire of the speaker cords are shorted.   | Switch the system to the standby mode, and reconnect the speaker cords so that they are not shorted. Then switch on the power. | 6  |
| "ERROR" message appears on the display.                                      | Incorrect operation has been done.   | Operate the unit correctly by following the operating instructions.  |    |
| "-- : --" appears on the display.  | <ul style="list-style-type: none"> <li>You plugged the power cord in for the first time.</li> <li>There was a power failure recently.</li> </ul> | Set the time.  | 11 |
| "F61" appears on the display.  | Check if the speaker cords have shorted.   | If they are not shorted then there is a power supply problem. Consult your dealer for assistance.                              |    |

| While listening to FM broadcasts   |  |   |   |
|--|--|---|---|
| There is a "rushing noise" during a stereo broadcast which is not audible during a monaural broadcast. | The transmitting station is a long distance away.  | If you are using an indoor antenna, change to an outdoor antenna.   | 7 |
| You hear excessive noise during a stereo broadcast, and occasionally the sound disappears.             | The installation location and orientation of the antenna are unsuitable.                   |   |   |
| The stereo indicator ("STEREO") flickers and does not light completely.                                | The transmitting station is a long distance away.<br>The power of the TV set or VCR is ON. | Try switching off the TV set or VCR.  |   |
| The sound during a stereo broadcast is highly distorted.   | There is a building or mountain nearby.  | Use a high-grade outdoor antenna, and install it in a good location, height, and orientation for reception. | 7 |

| While listening to AM broadcasts |   |  |  |
|----------------------------------|---|--|--|
| You hear an unusual beat sound.  | You are using the system at the same time you are playing a TV set. | Switch off the TV set, or use the system further away from it. |  |
| You hear a low-frequency hum.    | The antenna wire is near the power cord.                            | Separate the antenna wire from the power cord.                 |  |

| Problem | Probable cause(s) | Suggested remedy | Reference page(s) |
|---------|-------------------|------------------|-------------------|
|---------|-------------------|------------------|-------------------|

### When there is a television set nearby

|   |  |   |   |
|---|--|---|---|
| The picture on the TV disappears or stripes appear on the screen. | The location and orientation of the antenna are incorrect. | If you are using an indoor antenna, change to an outdoor antenna. | 7 |
|   | The wiring at the back of the system is unsuitable.        | Separate the antenna wire of the TV set from the system.          |   |

### While using the cassette deck

|   |  |  |           |
|---|--|--|-----------|
| Sound is low, intermittent, poor quality, noisy, scratchy, or unsteady. | Heads are dirty.   | Clean the heads.   | See below |
| The deck does not enter the recording mode.                             | The erase-prevention tabs are removed from the cassette. | Attach tape to cover the space left by removal of the erase-prevention tabs. | 20        |

### While listening to compact discs

|  |  |   |    |
|--|--|---|----|
| The display does not show the correct indication. Disc play does not start when you press the play button. | The disc is upside down.   | Set the disc with the label facing upward.  | 15 |
|  | The disc is dirty.   | Wipe the disc with a soft cloth.  | 14 |
|  | The disc is scratched.   | Replace the disc with a new one.  |    |
|  | The disc is badly warped.  |   |    |
|  | The disc is a nonstandard one.   | Replace the disc with a different one.  | 14 |
| There is condensation inside the CD changer.   | Wait for 60 minutes before using the CD player.  |   |    |
| A certain music passage can't be played correctly.   | The disc is dirty.   | Wipe the disc with a soft cloth.  | 14 |
| "TAKE OUT/DISC" appears on the display.  | There was a power failure or the power cord was disconnected from the household AC outlet <ul style="list-style-type: none"> <li>during disc changing operation or</li> <li>when the disc tray is opened.</li> </ul> | <ol style="list-style-type: none"> <li>Press [⏻], POWER] to switch on the power. The tray will open.</li> <li>If there is a CD in the tray, remove it, then press [▶] of [CD 1] to close the tray. The system will restore normal operation.</li> </ol> |    |

### While using the remote control

|  |  |  |   |
|--|--|--|---|
| The system cannot be operated with the remote control. | The batteries are installed in the reverse polarity. | Re-insert the batteries in the correct polarity. | 5 |
|  | The batteries are run-down.                          | Replace the batteries with new batteries.        | 5 |

## Maintenance

### If the surfaces are dirty

To clean this unit, wipe with a soft, dry cloth. If the surfaces are extremely dirty, use a soft cloth dipped in a soap-and-water solution or a weak detergent solution.

- Never use alcohol, paint thinner or benzine to clean this unit.
- Before using chemically treated cloth, read the instructions that came with the cloth carefully.

### For a cleaner crisper sound

Clean the heads regularly to assure good quality playback and recording. Use a cleaning tape (not included).

# Specifications

## AMPLIFIER SECTION

|                                    |                       |
|------------------------------------|-----------------------|
| <b>RMS power output</b>            |                       |
| 1% Total harmonic distortion       |                       |
| 1 kHz, both channels driven        | 45 W per channel (6Ω) |
| 1% Total harmonic distortion       |                       |
| 70 Hz–16 kHz, both channels driven | 40 W per channel (6Ω) |
| <b>Input sensitivity</b>           |                       |
| AUX                                | 250 mV                |
| <b>Input Impedance</b>             |                       |
| AUX                                | 13.9 kΩ               |

## FM TUNER SECTION

|                            |                                  |
|----------------------------|----------------------------------|
| <b>Frequency range</b>     |                                  |
|                            | 87.9 – 107.9 MHz (200 kHz steps) |
|                            | 87.5 – 108.0 MHz (100 kHz steps) |
| <b>Sensitivity</b>         | 2.5 μV (IHF)                     |
| S/N 26 dB                  | 2.2 μV                           |
| <b>Antenna terminal(s)</b> | 75 Ω (unbalanced)                |

## AM TUNER SECTION

|                         |                               |
|-------------------------|-------------------------------|
| <b>Frequency range</b>  |                               |
| AM                      | 520 – 1710 kHz (10 kHz steps) |
| <b>Sensitivity</b>      |                               |
| AM                      |                               |
| S/N 20 dB (at 1000 kHz) | 560 μV/m                      |

## CASSETTE DECK SECTION

|                                     |   |
|-------------------------------------|---|
| <b>Track system</b>                 | 4 track, 2 channel                          |
| <b>Heads</b>                        |   |
| Record/playback                     | Solid permalloy head                        |
| Erasure                             | Double gap ferrite head                     |
| <b>Motor</b>                        | DC servo motor                              |
| <b>Recording system</b>             | AC bias 100 kHz                             |
| <b>Erasing system</b>               | AC erase 100 kHz                            |
| <b>Tape speed</b>                   | 4.8 cm/s                                    |
| <b>Frequency response</b>           |   |
| (+3 dB, –6 dB at DECK OUT)          |   |
| NORMAL (TYPE I)                     | 35 Hz – 14 kHz                              |
| HIGH (TYPE II)                      | 35 Hz – 14 kHz                              |
| <b>S/N</b>                          | 50 dB (A weighted)                          |
| <b>Wow and flutter</b>              | 0.18% (WRMS)                                |
| <b>Fast forward and rewind time</b> |   |
|                                     | Approx. 120 seconds with C-60 cassette tape |

## CD SECTION

|                                |                            |
|--------------------------------|----------------------------|
| <b>Sampling frequency</b>      | 44.1 kHz                   |
| <b>Decoding</b>                | 16 bit linear              |
| <b>Beam source/wave length</b> | Semiconductor laser/780 nm |
| <b>Number of channels</b>      | Stereo                     |
| <b>Frequency response</b>      | 20 Hz–20 kHz (+1, –2 dB)   |
| <b>Wow and flutter</b>         | Below measurable limit     |
| <b>Digital filter</b>          | 8 fs                       |
| <b>D/A converter</b>           | MASH (1 bit DAC)           |

## SPEAKER SECTION

|                                    |   |
|------------------------------------|---|
| <b>Type</b>                        | 2 way speaker system  |
| <b>Speaker(s)</b>                  |   |
| Woofer                             | 12 cm (4 <sup>23</sup> / <sub>32</sub> " cone type                          |
| Tweeter                            | 6 cm (2 <sup>3</sup> / <sub>8</sub> " cone type                             |
| <b>Impedance</b>                   | 6 Ω   |
| <b>Input power</b>                 | 100 W (Music)   |
| <b>Output sound pressure level</b> | 85 dB/W (1.0 m)   |
| <b>Cross over frequency</b>        | 5 kHz   |
| <b>Frequency range</b>             | 45 Hz–22 kHz (–16 dB)   |
|                                    | 55 Hz–20 kHz (–10 dB)   |
| <b>Dimensions (WxHxD)</b>          | 210 x 330 x 257 mm  |
|                                    | (8 <sup>9</sup> / <sub>32</sub> " x 13" x 10 <sup>1</sup> / <sub>8</sub> ") |
| <b>Mass</b>                        | 3.0 kg (6.6 lb.)  |

## GENERAL

|                           |  |
|---------------------------|--|
| <b>Power supply</b>       | AC 120 V, 60 Hz  |
| <b>Power consumption</b>  | 145 W  |
| <b>Dimensions (WxHxD)</b> | 270 x 330 x 310 mm   |
|                           | (10 <sup>5</sup> / <sub>8</sub> " x 13" x 12 <sup>7</sup> / <sub>32</sub> ") |
| <b>Mass</b>               | 6.8 kg (14.96 lb.)   |

### Power consumption in standby mode

|              |        |
|--------------|--------|
| Eco mode on  | 0.25 W |
| Eco mode off | 18 W   |

### Notes:

- Specifications are subject to change without notice.  
Mass and dimensions are approximate.
- Total harmonic distortion is measured by the digital spectrum analyzer.

## Product service

Do not attempt to remove the cover(s) or repair the unit yourself.  
Refer servicing to qualified personnel only.

## Product information

For product service, product information or assistance with product operation, refer to the servicenter directory.

Panasonic Consumer Electronics  
Company, Division of Matsushita  
Electric Corporation of America  
One Panasonic Way Secaucus,  
New Jersey 07094  
<http://www.panasonic.com>

Panasonic Sales Company,  
Division of Matsushita Electric of  
Puerto Rico, Inc. ("PSC")  
Ave. 65 de Infantería, Km. 9.5  
San Gabriel Industrial Park, Carolina,  
Puerto Rico 00985

En